

MESLEKİ YABANCI DİL I DÖNEM ÖDEVİ

NO	ADI SOYADI	Bölüm	Sayfa
000502017	ERKAN KÜÇÜKÖNDER	9.1 Introduction	9-1/9-10
010502009	HÜSEYİN ÖZDOĞAN		
020502009	FIRAT ÇAVUŞ		
020502014	ERDOĞAN ATEŞ		
020502021	ERCAN KARAKAN		
020502028	AYHAN ALTINTAŞ	9.4 Refrigerants and Refrigeration Cycles	9-34/9-47
030502001	EMRAH ALTUN		
030502004	RECEP AYTAÇ İZGÖRDÜ		
030502012	CENGİZ AYHAN		
030502014	SELAHATTİN ŞAHİN		
030502015	AHMET TEKER	9.7 Air Handling Units and Packaged Units	9-65/9-75
030502027	METİN TİMUÇİN		
040502008	YÜCEL YILDIRIM		
040502020	MAHMUT KEÇECİ		
040502028	CEMİL BELEN		
040502033	ERDAL ESEN	9.8 Refrigeration Components and Evaporative Coolers	9-76/9-86
040502034	MUSTAFA MURAT ŞAHİN		
040502035	TALAT ÇETKİN		
040502036	ADEM ONATER		

Not:

- 1- Verilen ödev grup çalışması olduğundan ödevlerin çıktısında herkesin imzası olacaktır.
- 2- Ödevler bilgisayar çıktısı ve elektronik dosya olarak 24 Ocak 2007'den önce teslim edilecektir.
- 3- Şekil ve tablolar da çevrilecektir. Konu bütünlüğüne dikkat edilecektir. Teknik kelimeler için http://www.ttmd.org.tr/trfiles/sozluk_eng.asp adresine başvurulabilir.

Air-Conditioning and Refrigeration

Shan K. Wang
Individual Consultant

Zalman Lavan
*Professor Emeritus, Illinois
Institute of Technology*

9.1	Introduction	9-2
	Air-conditioning • Air-Conditioning Systems • Air-Conditioning Project Development and System Design	
9.2	Psychrometrics	9-11
	Moist Air • Humidity and Enthalpy • Moist Volume, Density, Specific Heat, and Dew Point • Thermodynamic Wet Bulb Temperature and Wet Bulb Temperature • Psychrometric Charts	
9.3	Air-Conditioning Processes and Cycles	9-18
	Air-Conditioning Processes • Space Conditioning, Sensible Cooling, and Sensible Heating Processes • Humidifying and Cooling and Dehumidifying Processes • Air-Conditioning Cycles and Operating Modes	
9.4	Refrigerants and Refrigeration Cycles	9-34
	Refrigeration and Refrigeration Systems • Refrigerants, Cooling Mediums, and Absorbents • Classification of Refrigerants • Required Properties of Refrigerants • Ideal Single-Stage Vapor Compression Cycle • Coefficient of Performance of Refrigeration Cycle • Subcooling and Superheating • Refrigeration Cycle of Two-Stage Compound Systems with a Flash Cooler • Cascade System Characteristics	
9.5	Outdoor Design Conditions and Indoor Design Criteria	9-48
	Outdoor Design Conditions • Indoor Design Criteria and Thermal Comfort • Indoor Temperature, Relative Humidity, and Air Velocity • Indoor Air Quality and Outdoor Ventilation Air Requirements	
9.6	Load Calculations	9-54
	Space Loads • Moisture Transfer in Building Envelope • Cooling Load Calculation Methodology • Conduction Heat Gains • Internal Heat Gains • Conversion of Heat Gains into Cooling Load by TFM • Heating Load	
9.7	Air Handling Units and Packaged Units	9-65
	Terminals and Air Handling Units • Packaged Units • Coils • Air Filters • Humidifiers	
9.8	Refrigeration Components and Evaporative Coolers	9-76
	Refrigeration Compressors • Refrigeration Condensers • Evaporators and Refrigerant Flow Control Devices • Evaporative Coolers	

9.9	Water Systems	9-87
	Types of Water Systems • Basics • Water Piping • Plant-Building Loop • Plant-Distribution-Building Loop	
9.10	Heating Systems	9-95
	Types of Heating Systems	
9.11	Refrigeration Systems	9-103
	Classifications of Refrigeration Systems	
9.12	Thermal Storage Systems	9-114
	Thermal Storage Systems and Off-Peak Air-Conditioning Systems • Ice-Storage Systems • Chilled-Water Storage Systems	
9.13	Air System Basics	9-120
	Fan-Duct Systems • System Effect • Modulation of Air Systems • Fan Combinations in Air-Handling Units and Packaged Units • Fan Energy Use • Year-Round Operation and Economizers • Outdoor Ventilation Air Supply	
9.14	Absorption Systems	9-130
	Double-Effect Direct-Fired Absorption Chillers • Absorption Cycles, Parallel-, Series-, and Reverse-Parallel Flow	
9.15	Air-Conditioning Systems and Selection	9-135
	Basics in Classification • Individual Systems • Packaged Systems • Central Systems • Air-Conditioning System Selection • Comparison of Various Systems • Subsystems • Energy Conservation Recommendations	
9.16	Desiccant Dehumidification and Air-Conditioning	9-152
	Introduction • Sorbents and Desiccants • Dehumidification • Liquid Spray Tower • Solid Packed Tower • Rotary Desiccant Dehumidifiers • Hybrid Cycles • Solid Desiccant Air-Conditioning • Conclusions	

9.1 Introduction

Air-Conditioning

Air-conditioning is a process that simultaneously conditions air; distributes it combined with the outdoor air to the conditioned space; and at the same time controls and maintains the required space's temperature, humidity, air movement, air cleanliness, sound level, and pressure differential within predetermined limits for the health and comfort of the occupants, for product processing, or both.

The acronym HVAC&R stands for heating, ventilating, air-conditioning, and refrigerating. The combination of these processes is equivalent to the functions performed by air-conditioning.

Because I-P units are widely used in the HVAC&R industry in the U.S., I-P units are used in this chapter. A table for converting I-P units to SI units is available in Appendix X of this handbook.

Air-Conditioning Systems

An *air-conditioning* or *HVAC&R system* consists of components and equipment arranged in sequential order to heat or cool, humidify or dehumidify, clean and purify, attenuate objectionable equipment noise, transport the conditioned outdoor air and recirculate air to the conditioned space, and control and maintain an indoor or enclosed environment at optimum energy use.

The types of buildings which the air-conditioning system serves can be classified as:

- Institutional buildings, such as hospitals and nursing homes
- Commercial buildings, such as offices, stores, and shopping centers

- Residential buildings, including single-family and multifamily low-rise buildings of three or fewer stories above grade
- Manufacturing buildings, which manufacture and store products

Types of Air-Conditioning Systems

In institutional, commercial, and residential buildings, air-conditioning systems are mainly for the occupants' health and comfort. They are often called *comfort air-conditioning systems*. In manufacturing buildings, air-conditioning systems are provided for product processing, or for the health and comfort of workers as well as processing, and are called *processing air-conditioning systems*.

Based on their size, construction, and operating characteristics, air-conditioning systems can be classified as the following.

Individual Room or Individual Systems. An individual air-conditioning system normally employs either a single, self-contained, packaged room air conditioner (installed in a window or through a wall) or separate indoor and outdoor units to serve an individual room, as shown in [Figure 9.1.1](#). “Self-contained, packaged” means factory assembled in one package and ready for use.

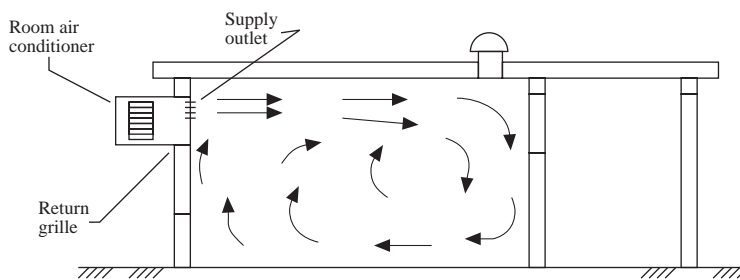

FIGURE 9.1.1 An individual room air-conditioning system.

Space-Conditioning Systems or Space Systems. These systems have their air-conditioning—cooling, heating, and filtration—performed predominantly in or above the conditioned space, as shown in [Figure 9.1.2](#). Outdoor air is supplied by a separate outdoor ventilation system.

Unitary Packaged Systems or Packaged Systems. These systems are installed with either a single self-contained, factory-assembled packaged unit (PU) or two split units: an indoor air handler, normally with ductwork, and an outdoor condensing unit with refrigeration compressor(s) and condenser, as shown in [Figure 9.1.3](#). In a packaged system, air is cooled mainly by direct expansion of refrigerant in coils called DX coils and heated by gas furnace, electric heating, or a heat pump effect, which is the reverse of a refrigeration cycle.

Central Hydronic or Central Systems. A central system uses chilled water or hot water from a central plant to cool and heat the air at the coils in an air handling unit (AHU) as shown in [Figure 9.1.4](#). For energy transport, the heat capacity of water is about 3400 times greater than that of air. Central systems are built-up systems assembled and installed on the site.

Packaged systems are comprised of only air system, refrigeration, heating, and control systems. Both central and space-conditioning systems consist of the following.

Air Systems. An air system is also called an air handling system or the air side of an air-conditioning or HVAC&R system. Its function is to condition the air, distribute it, and control the indoor environment according to requirements. The primary equipment in an air system is an AHU or air handler; both of these include fan, coils, filters, dampers, humidifiers (optional), supply and return ductwork, supply outlets and return inlets, and controls.

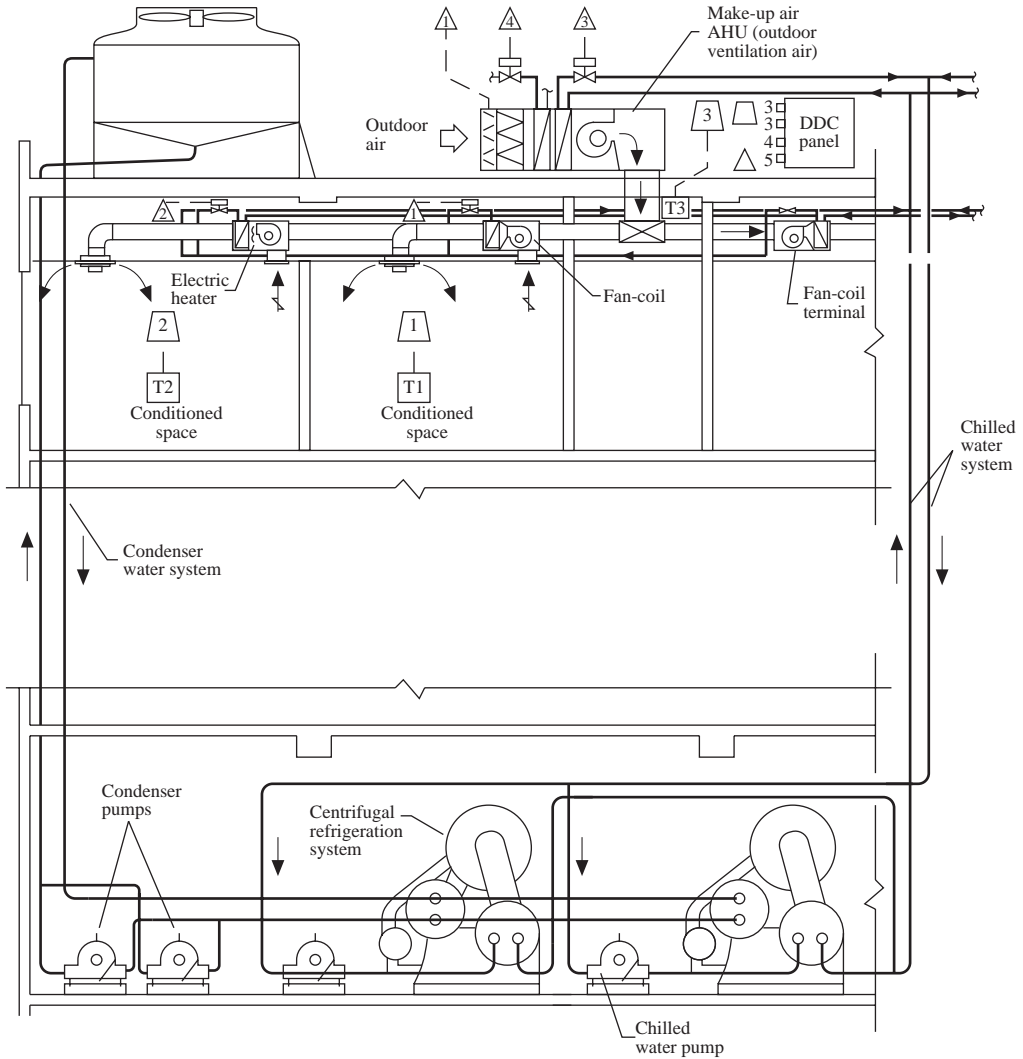

FIGURE 9.1.2 A space-conditioning air-conditioning system (fan-coil system).

Water Systems. These systems include chilled water, hot water, and condenser water systems. A water system consists of pumps, piping work, and accessories. The water system is sometimes called the water side of a central or space-conditioning system.

Central Plant Refrigeration and Heating Systems. The refrigeration system in the central plant of a central system is usually in the form of a chiller package with an outdoor condensing unit. The refrigeration system is also called the refrigeration side of a central system. A boiler and accessories make up the heating system in a central plant for a central system, and a direct-fired gas furnace is often the heating system in the air handler of a rooftop packaged system.

Control Systems. Control systems usually consist of sensors, a microprocessor-based direct digital controller (DDC), a control device, control elements, personal computer (PC), and communication network.

Based on Commercial Buildings Characteristics 1992, Energy Information Administration (EIA) of the Department of Energy of United States in 1992, for commercial buildings having a total floor area

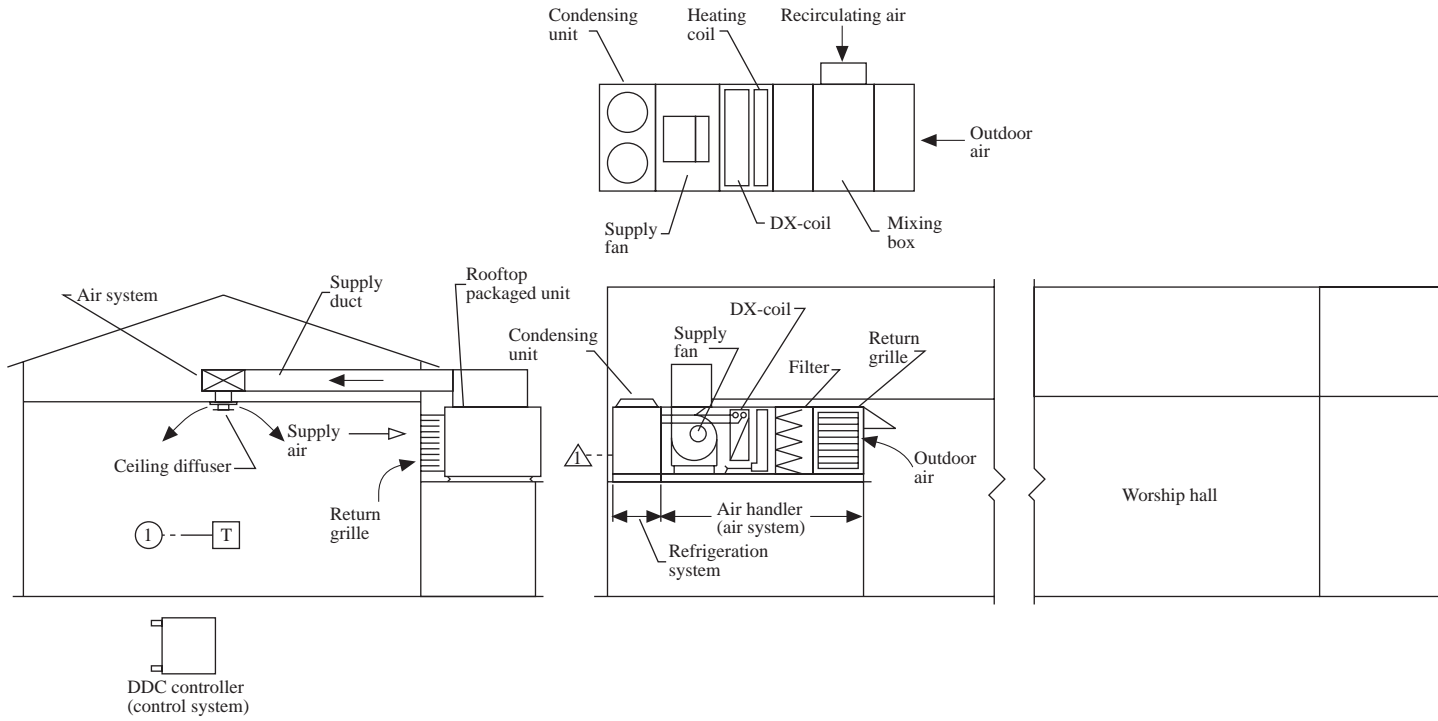

FIGURE 9.1.3 A packaged air-conditioning system.

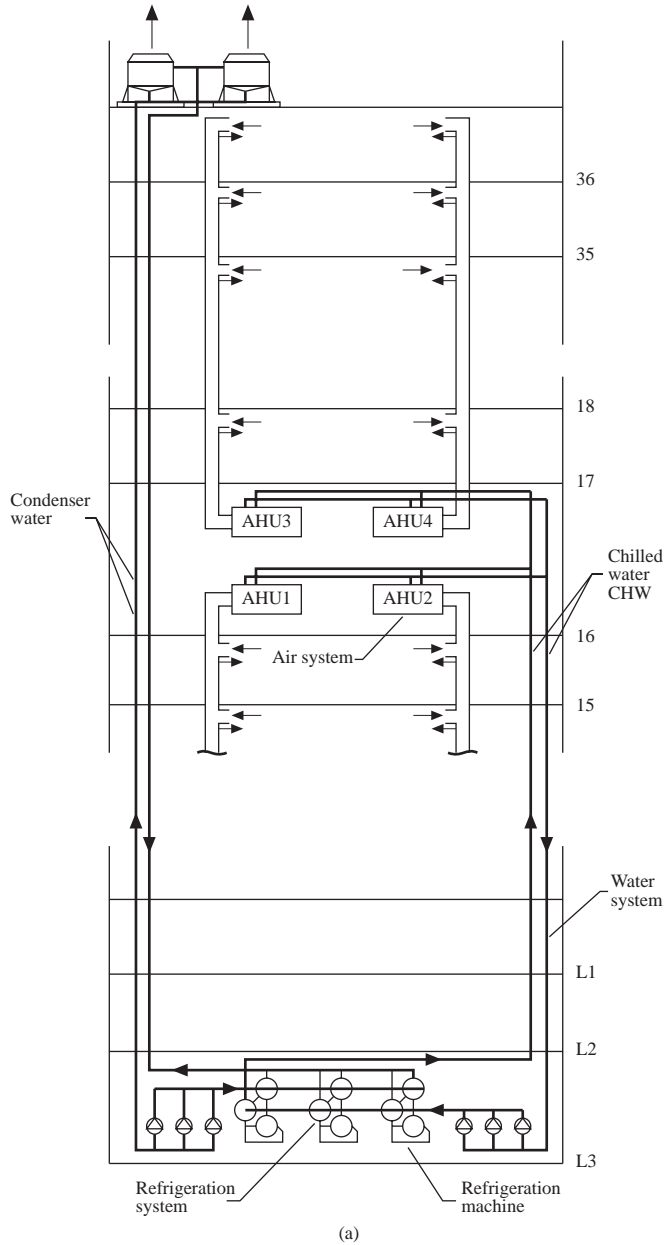

FIGURE 9.1.4a A central air-conditioning system: schematic diagram.

of 67,876 million ft², of which 57,041 million ft² or 84% is cooled and 61,996 million ft² or 91% is heated, the air-conditioning systems for cooling include:

Individual systems	19,239 million ft ²	(25%)
Packaged systems	34,753 million ft ²	(49%)
Central systems	14,048 million ft ²	(26%)

Space-conditioning systems are included in central systems. Part of the cooled floor area has been counted for both individual and packaged systems. The sum of the floor areas for these three systems therefore exceeds the total cooled area of 57,041 million ft².

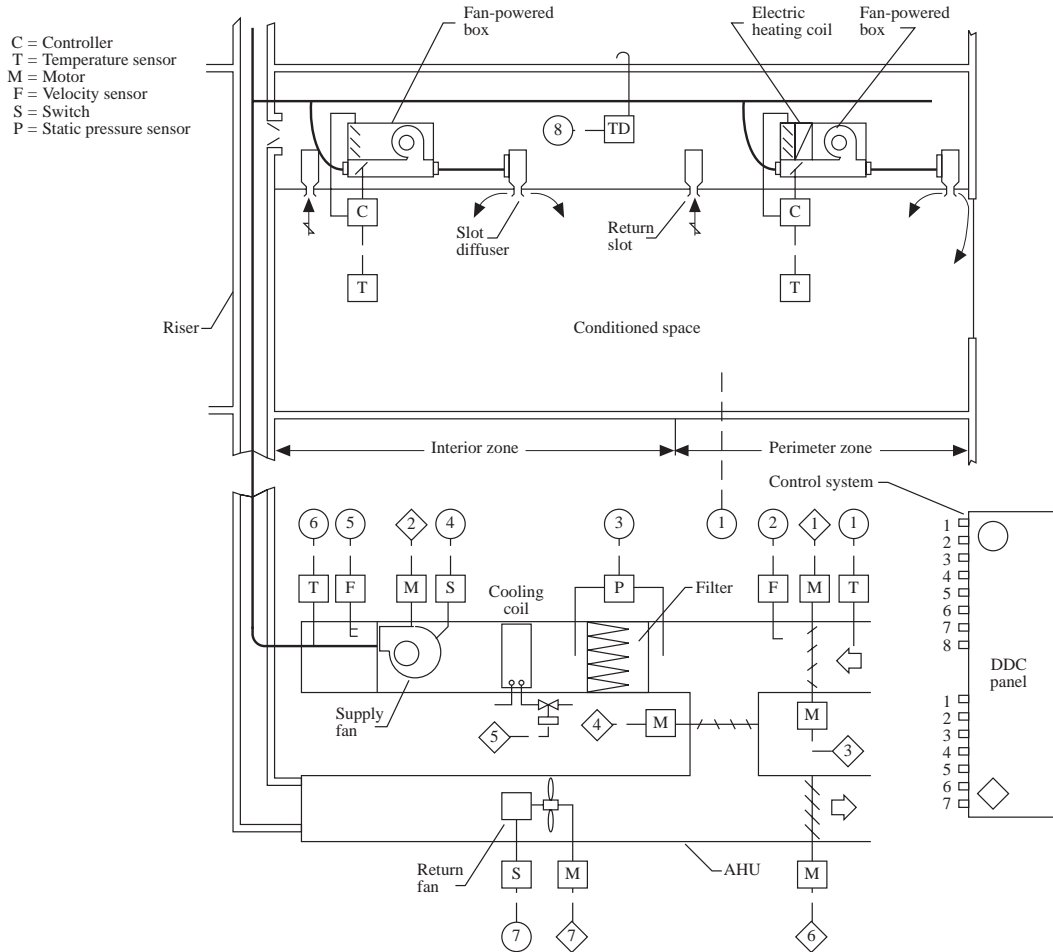

FIGURE 9.1.4b A central air-conditioning system: air and control systems for a typical floor.

Air-Conditioning Project Development and System Design

The goal of an air-conditioning/HVAC&R system is to provide a healthy and comfortable indoor environment with acceptable indoor air quality, while being energy efficient and cost effective.

ASHRAE Standard 62-1989 defines *acceptable indoor air quality* as “air in which there are no known contaminants at harmful concentrations as determined by cognizant authorities and with which a substantial majority (80% or more) of the people exposed do not express dissatisfaction.”

The basic steps in the development and use of an air-conditioning project are design, installation, commissioning, operation, and maintenance. There are two types of air-conditioning projects: *design-bid* and *design-build*. A design-bid project separates the design (engineering consultant) and installation (contractors) responsibilities. In a design-build project, the design is also done by the installation contractor. A design-build project is usually a small project or a project having insufficient time to go through normal bidding procedures.

In the building construction industry, air-conditioning or HVAC&R is one of the *mechanical services*; these also include plumbing, fire protection, and escalators.

Air-conditioning design is a process of selecting the optimum system, subsystem, equipment, and components from various alternatives and preparing the drawings and specifications. Haines (1994) summarized this process in four phases: gather information, develop alternatives, evaluate alternatives,

and sell the best solution. Design determines the basic operating characteristics of a system. After an air-conditioning system is designed and constructed, it is difficult and expensive to change its basic characteristics.

The foundation of a successful project is teamwork and coordination between designer, contractor, and operator and between mechanical engineer, electrical engineer, facility operator, architect, and structural engineer.

Field experience is helpful to the designer. Before beginning the design process it is advisable to visit similar projects that have operated for more than 2 years and talk with the operator to investigate actual performance.

Mechanical Engineer's Responsibilities

The normal procedure in a design-bid construction project and the mechanical engineer's responsibilities are

1. Initiation of a project by owner or developer
2. Organizing a design team
3. Determining the design criteria and indoor environmental parameters
4. Calculation of cooling and heating loads
5. Selection of systems, subsystems, and their components
6. Preparation of schematic layouts; sizing of piping and ductwork
7. Preparation of contract documents: drawings and specifications
8. Competitive biddings by various contractors; evaluation of bids; negotiations and modifications
9. Advice on awarding of contract
10. Monitoring, supervision, and inspection of installation; reviewing shop drawings
11. Supervision of commissioning
12. Modification of drawings to the as-built condition; preparation of the operation and maintenance manual
13. Handing over to the property management for operation

Design Documents

Drawings and *specifications* are legal documents of a construction contract. The designer conveys the owner's or developer's requirements to the contractor through these documents. Drawings and specifications complement each other.

Drawings should clearly and completely show, define, and present the work. Adequate plan and sectional views should be drawn. More often, isometric drawings are used to show the flow diagrams for water or the supply, return, and exhaust air.

Specifications include the legal contract between the owner and the contractor, installer, or vendor and the technical specifications, which describe in detail what kind of material and equipment should be used and how they are to be installed.

Most projects now use a format developed by the Construction Specifications Institute (CSI) called the Masterformat for Specifications. It includes 16 divisions. The 15000 Mechanical division is divided into the following:

Section No.	Title
15050	Basic Mechanical Materials and Methods
15250	Mechanical Insulation
15300	Fire Protection
15400	Plumbing
15500	Heating, Ventilating, and Air-Conditioning
15550	Heat Generation
15650	Refrigeration
15750	Heat Transfer
15850	Air Handling

Section No.	Title
15880	Air Distribution
15950	Controls
15990	Testing, Adjusting, and Balancing

Each section includes general considerations, equipment and material, and field installation. Design criteria and selected indoor environmental parameters that indicate the performance of the HVAC&R system must be clearly specified in the general consideration of Section 15500.

There are two types of specifications: the performance specification, which depends mainly on the required performance criteria, and the or-equal specification, which specifies the wanted vendor. Specifications should be written in simple, direct, and clear language without repetition.

Computer-Aided Design and Drafting

With the wide acceptance of the PC and the availability of numerous types of engineering software, the use of *computer-aided drafting* (CAD) and *computer-aided design and drafting* (CADD) has increased greatly in recent years. According to the 1994 CADD Application and User Survey of design firms reported in *Engineering Systems* (1994[6]), “15% of the design firms now have a computer on every desk” and “Firms with high productivity reported that they perform 95% on CADD.” Word processing software is widely used to prepare specifications.

Drafting software used to reproduce architectural drawings is the foundation of CADD. Automated CAD (AutoCAD) is the leading personal computer-based drafting tool software used in architectural and engineering design firms.

In “Software Review” by Amistadi (1993), duct design was the first HVAC&R application to be integrated with CAD.

- Carrier Corp. DuctLINK and Softdesk HVAC 12.0 are the two most widely used duct design software. Both of them convert the single-line duct layout drawn with CAD to two-dimensional (2D) double-line drawings with fittings, terminals, and diffusers.
- Tags and schedules of HVAC&R equipment, ductwork, and duct fittings can be produced as well.
- DuctLINK and Softdesk can also interface with architectural, electrical, and plumbing drawings through AutoCAD software.

Software for piping system design and analysis can also be integrated with CAD. The software developed at the University of Kentucky, KYCAD/KYPIPE, is intended for the design and diagnosis of large water piping systems, has extensive hydraulic modeling capacities, and is the most widely used. Softdesk AdCADD Piping is relative new software; it is intended for drafting in 2D and 3D, linking to AutoCAD through design information databases.

Currently, software for CADD for air-conditioning and HVAC&R falls into two categories: engineering and product. The engineering category includes CAD (AutoCAD integrated with duct and piping system), load calculations and energy analysis, etc. The most widely used software for load calculations and energy analysis is Department of Energy DOE-2.1D, Trane Company’s TRACE 600, and Carrier Corporation’s softwares for load calculation, E20-II Loads.

Product categories include selection, configuration, performance, price, and maintenance schedule. Product manufacturers provide software including data and CAD drawings for their specific product.

Codes and Standards

Codes are federal, state, or city laws that require the designer to perform the design without violating people’s (including occupants and the public) safety and welfare. Federal and local codes must be followed. The designer should be thoroughly familiar with relevant codes. HVAC&R design codes are definitive concerning structural and electrical safety, fire prevention and protection (particularly for gas- or oil-fired systems), environmental concerns, indoor air quality, and energy conservation.

Conformance with *ASHRAE Standards* is voluntary. However, for design criteria or performance that has not been covered in the codes, whether the ASHRAE Standard is followed or violated is the vital criterion, as was the case in a recent indoor air quality lawsuit against a designer and contractor.

For the purpose of performing an effective, energy-efficient, safe, and cost-effective air-conditioning system design, the following ASHRAE Standards should be referred to from time to time:

- ASHRAE/IES Standard 90.1-1989, Energy Efficient Design of New Buildings Except New Low-Rise Residential Buildings
- ANSI/ASHRAE Standard 62-1989, Ventilation for Acceptable Indoor Air Quality
- ANSI/ASHRAE Standard 55-1992, Thermal Environmental Conditions for Human Occupancy
- ASHRAE Standard 15-1992, Safety Code for Mechanical Refrigeration

9.4 Refrigerants and Refrigeration Cycles

Refrigeration and Refrigeration Systems

Refrigeration is the cooling effect of the process of extracting heat from a lower temperature heat source, a substance or cooling medium, and transferring it to a higher temperature heat sink, probably atmospheric air and surface water, to maintain the temperature of the heat source below that of the surroundings.

A *refrigeration system* is a combination of components, equipment, and piping, connected in a sequential order to produce the refrigeration effect. Refrigeration systems that provide cooling for air-conditioning are classified mainly into the following categories:

1. *Vapor compression systems.* In these systems, a compressor(s) compresses the refrigerant to a higher pressure and temperature from an evaporated vapor at low pressure and temperature. The compressed refrigerant is condensed into liquid form by releasing the latent heat of condensation to the condenser water. Liquid refrigerant is then throttled to a low-pressure, low-temperature vapor, producing the refrigeration effect during evaporation. Vapor compression is often called *mechanical refrigeration*, that is, refrigeration by mechanical compression.
2. *Absorption systems.* In an absorption system, the refrigeration effect is produced by means of thermal energy input. After liquid refrigerant produces refrigeration during evaporation at very low pressure, the vapor is absorbed by an aqueous absorbent. The solution is heated by a direct-fired gas furnace or waste heat, and the refrigerant is again vaporized and then condensed into liquid form. The liquid refrigerant is throttled to a very low pressure and is ready to produce the refrigeration effect again.
3. *Gas expansion systems.* In an air or other gas expansion system, air or gas is compressed to a high pressure by compressors. It is then cooled by surface water or atmospheric air and expanded to a low pressure. Because the temperature of air or gas decreases during expansion, a refrigeration effect is produced.

Refrigerants, Cooling Mediums, and Absorbents

A *refrigerant* is a primary working fluid used to produce refrigeration in a refrigeration system. All refrigerants extract heat at low temperature and low pressure during evaporation and reject heat at high temperature and pressure during condensation.

A *cooling medium* is a working fluid cooled by the refrigerant during evaporation to transport refrigeration from a central plant to remote cooling equipment and terminals. In a large, centralized air-conditioning system, it is more economical to pump the cooling medium to the remote locations where cooling is required. Chilled water and brine are cooling media. They are often called secondary refrigerants to distinguish them from the primary refrigerants.

A *liquid absorbent* is a working fluid used to absorb the vaporized refrigerant (water) after evaporation in an absorption refrigeration system. The solution that contains the absorbed vapor is then heated. The refrigerant vaporizes, and the solution is restored to its original concentration to absorb water vapor again.

A numbering system for refrigerants was developed for hydrocarbons and halocarbons. According to ANSI/ASHRAE Standard 34-1992, the first digit is the number of unsaturated carbon-carbon bonds in the compound. This digit is omitted if the number is zero. The second digit is the number of carbon atoms minus one. This is also omitted if the number is zero. The third digit denotes the number of hydrogen atoms plus one. The last digit indicates the number of fluorine atoms. For example, the chemical formula for refrigerant R-123 is CHCl_2CF_3 . In this compound:

No unsaturated carbon-carbon bonds, first digit is 0
 There are two carbon atoms, second digit is 2 - 1 = 1
 There is one hydrogen atom, third digit is 1 + 1 = 2

There are three fluorine atoms, last digit is 3

To compare the relative ozone depletion of various refrigerants, an index called the *ozone depletion potential* (ODP) has been introduced. ODP is defined as the ratio of the rate of ozone depletion of 1 lb of any halocarbon to that of 1 lb of refrigerant R-11. For R-11, ODP = 1.

Similar to the ODP, halocarbon global warming potential (HGWP) is an index used to compare the global warming effect of a halocarbon refrigerant with the effect of refrigerant R-11.

Classification of Refrigerants

Nontoxic and nonflammable synthetic chemical compounds called *halogenated hydrocarbons*, or simply *halocarbons*, were used almost exclusively in vapor compression refrigeration systems for comfort air-conditioning until 1986. Because chlorofluorocarbons (CFCs) cause ozone depletion and global warming, they must be replaced. A classification of refrigerants based on ozone depletion follows (see [Table 9.4.1](#)):

Hydrofluorocarbons (HFCs)

HFCs contain only hydrogen, fluorine, and carbon atoms and cause no ozone depletion. HFCs group include R-134a, R-32, R-125, and R-245ca.

HFC's Azeotropic Blends or Simply HFC's Azeotropic

An azeotropic is a mixture of multiple components of volatilities (refrigerants) that evaporate and condense as a single substance and do not change in volumetric composition or saturation temperature when they evaporate or condense at constant pressure. HFC's azeotropics are blends of refrigerant with HFCs. ASHRAE assigned numbers between 500 and 599 for azeotropic. HFC's azeotropic R-507, a blend of R-125/R-143, is the commonly used refrigerant for low-temperature vapor compression refrigeration systems.

HFC's Near Azeotropic

A near azeotropic is a mixture of refrigerants whose characteristics are near those of an azeotropic. Because the change in volumetric composition or saturation temperature is rather small for a near azeotropic, such as, 1 to 2°F, it is thus named. ASHRAE assigned numbers between 400 and 499 for zeotropic. R-404A (R-125/R-134a/R-143a) and R-407B (R-32/R-125/R134a) are HFC's near azeotropic. R-32 is flammable; therefore, its composition is usually less than 30% in the mixture. HFC's near azeotropic are widely used for vapor compression refrigeration systems.

Zeotropic or nonazeotropic, including near azeotropic, shows a change in composition due to the difference between liquid and vapor phases, leaks, and the difference between charge and circulation. A shift in composition causes the change in evaporating and condensing temperature/pressure. The difference in dew point and bubble point during evaporation and condensation is called glide, expressed in °F. Near azeotropic has a smaller glide than zeotropic. The midpoint between the dew point and bubble point is often taken as the evaporating and condensing temperature for refrigerant blends.

Hydrochlorofluorocarbons (HCFCs) and Their Zeotropics

HCFCs contain hydrogen, chlorine, fluorine, and carbon atoms and are not fully halogenated. HCFCs have a much shorter lifetime in the atmosphere (in decades) than CFCs and cause far less ozone depletion (ODP 0.02 to 0.1). R-22, R-123, R-124, etc. are HCFCs. HCFCs are the most widely used refrigerants today.

HCFC's near azeotropic and *HCFC's zeotropic* are blends of HCFCs with HFCs. They are transitional or interim refrigerants and are scheduled for a restriction in production starting in 2004.

Inorganic Compounds

These compounds include refrigerants used before 1931, like ammonia R-717, water R-718, and air R-729. They are still in use because they do not deplete the ozone layer. Because ammonia is toxic and

TABLE 9.4.1 Properties of Commonly Used Refrigerants 40°F Evaporating and 100°F Condensing

		Chemical Formula	Molecular Mass	Ozone Depletion Potential (ODP)	Global Warming Potential (HGWP)	Evaporating Pressure, psia	Condensing Pressure, psia	Compression Ratio	Refrigeration Effect, Btu/lb
Hydrofluorocarbons HFCs									
R-32	Difluoromethane	CH ₂ F ₂	52.02	0.0	0.14	135.6	340.2	2.51	
R-125	Pentafluoroethane	CHF ₂ CF ₃	120.03	0.0	0.84	111.9	276.2	2.47	37.1
R-134a	Tetrafluoroethane	CF ₃ CH ₂ F	102.03	0.0	0.26	49.7	138.8	2.79	65.2
R-143a	Trifluoroethane	CH ₃ CF ₃	84.0	0.0					
R-152a	Difluoroethane	CH ₃ CHF ₂	66.05	0.0		44.8	124.3	2.77	
R-245ca	Pentafluoropropane	CF ₃ CF ₂ CH ₃	134.1	0.0					
HFC's azeotropics									
R-507	R-125/R-143 (45/55)			0.0	0.98				
HFC's near azeotropic									
R-404A	R-125/R-143a (44/52/4)			0.0	0.94				
R-407A	R-32/R-125/R-134a (20/40/40)			0.0	0.49				
R-407C	R-32/R-125/R-134a (23/25/52)			0.0	0.70				
Hydrochlorofluorocarbons HCFCs and their azeotropics									
R-22	Chlorodifluoromethane	CHClF ₂	86.48	0.05	0.40	82.09	201.5	2.46	69.0
R-123	Dichlorotrifluoroethane	CHCl ₂ CF ₃	152.93	0.02	0.02	5.8	20.8	3.59	62.9
R-124	Chlorotetrafluoroethane	CHFClCF ₃	136.47	0.02		27.9	80.92	2.90	5.21
HCFC's near azeotropics									
R-402A	R-22/R-125/R-290 (38/60/2)			0.02	0.63				
HCFC's azeotropics									
R-401A	R-22/R-124/R-152a (53/34/13)			0.37	0.22				
R-401B	R-22/R-124/R-152a (61/28/11)			0.04	0.24				

TABLE 9.4.1 Properties of Commonly Used Refrigerants 40°F Evaporating and 100°F Condensin (continued)

		Chemical Formula	Molecular Mass	Ozone Depletion Potential (ODP)	Global Warming Potential (HGWP)	Evaporating Pressure, psia	Condensing Pressure, psia	Compression Ratio	Refrigeration Effect, Btu/lb
Inorganic compounds									
R-717	Ammonia	NH ₃	17.03	0	0	71.95	206.81	2.87	467.4
R-718	Water	H ₂ O	18.02	0					
R-729	Air		28.97	0					
Chlorofluorocarbons CFCs, halons BFCs and their azeotropic									
R-11	Trichlorofluoromethane	CCl ₃ F	137.38	1.00	1.00	6.92	23.06	3.33	68.5
R-12	Dichlorodifluoromethane	CCl ₂ F ₂	120.93	1.00	3.20	50.98	129.19	2.53	50.5
R-13B1	Bromotrifluoromethane	CBrF ₃	148.93	10					
R-113	Trichlorotrifluoroethane	CCl ₃ FCF ₂	187.39	0.80	1.4	2.64	10.21	3.87	54.1
R-114	Dichlorotetrafluoroethane	CCl ₂ FCF ₃	170.94	1.00	3.9	14.88	45.11	3.03	42.5
R-500	R-12/R-152a (73.8/26.2)		99.31			59.87	152.77	2.55	60.5
R-502	R-22/R-115 (48.8/51.2)		111.63	0.283	4.10				

TABLE 9.4.1 Properties of Commonly Used Refrigerants 40°F Evaporating and 100°F Condensing (continued)

Replacement of	Trade Name	Specific Volume of Vapor ft ³ /lb	Compressor Displacement cfm/ton	Power Consumption hp/ton	Critical Temperature °F	Discharge Temperature °F	Flammability	Safety
Hydrofluorocarbons HFCs								
		0.63			173.1			
		0.33			150.9	103	Nonflammable	A1
	R-12	0.95			213.9		Nonflammable	A1
	R143a							
	R-152a	1.64			235.9		Lower flammable	A2
	R-245ca							
HFC's azeotropics								
	R-502							
	Genetron AZ-50							
HFC's near azeotropic								
	R-22							A1/A1 ^a
	SUVA HP-62							A1/A1 ^a
	R-22							A1/A1 ^a
	KLEA 60							A1/A1 ^a
	R-22							A1/A1 ^a
	KLEA 66							A1/A1 ^a
Hydrochlorofluorocarbons HCFC's and their azeotropics								
		0.66	1.91	0.696	204.8	127	Nonflammable	A1
	R-11	5.88	18.87	0.663	362.6		Nonflammable	B1
		1.30	5.06	0.698	252.5			
HCFC's near azeotropics								
	R-502							A1/A1 ^a
	SUVA HP-80							A1/A1 ^a
HCFC's azeotropics								
	R-12							A1/A1 ^a
	MP 39							A1/A1 ^a
	R-12							A1/A1 ^a
	MP 66							A1/A1 ^a
Inorganic compounds								
		3.98	1.70	0.653	271.4	207	Lower flammability	B2
							Nonflammable	
							Nonflammable	

TABLE 9.4.1 Properties of Commonly Used Refrigerants 40°F Evaporating and 100°F Condensing (continued)

Replacement of	Trade Name	Specific Volume of Vapor ft ³ /lb	Compressor Displacement cfm/ton	Power Consumption hp/ton	Critical Temperature °F	Discharge Temperature °F	Flammability	Safety
Chlorofluorocarbons CFCs, halons BFCs, and their azeotropics								
	R-11	5.43	15.86	0.636	388.4	104	Nonflammable	A1
	R-12	5.79	3.08	0.689	233.6	100	Nonflammable	A1
	R-13B1	0.21			152.6	103	Nonflammable	A1
	R-113	10.71	39.55	0.71	417.4	86	Nonflammable	A1
	R-114	2.03	9.57	0.738	294.3	86	Nonflammable	A1
	R-500 R-12/R-152a (73.8/26.2)	0.79	3.62	0.692	221.9	105	Nonflammable	A1
	R-502 R-22/R-115 (48.8/51.2)					98	Nonflammable	A1

Source: Adapted with permission from *ASHRAE Handbooks 1993 Fundamentals*. Also from refrigerant manufacturers.

^a First classification is that safety classification of the formulated composition. The second is the worst case of fractionation.

flammable, it is used in industrial applications. Inorganic compounds are assigned numbers between 700 and 799 by ASHRAE.

Chlorofluorocarbons, Halons, and Their Azeotropic

CFCs contain only chlorine, fluorine, and carbon atoms. CFCs have an atmospheric lifetime of centuries and cause ozone depletion (ODP from 0.6 to 1). R-11, R-12, R-113, R-114, R-115... are all CFCs.

Halons or BFCs contain bromide, fluorine, and carbon atoms. R-13B1 and R-12B1 are BFCs. They cause very high ozone depletion (ODP for R-13B1 = 10). Until 1995, R-13B1 was used for very low temperature vapor compression refrigeration systems.

Phaseout of CFCs, BFCs, HCFCs, and Their Blends

On September 16, 1987, the European Economic Community and 24 nations, including the United States, signed a document called the Montreal Protocol. It is an agreement to restrict the production and consumption of CFCs and BFCs in the 1990s because of ozone depletion.

The Clean Air Act amendments, signed into law in the United States on November 15, 1990, concern two important issues: the phaseout of CFCs and the prohibition of deliberate venting of CFCs and HCFCs.

In February 1992, President Bush called for an accelerated ban of CFCs in the United States. In late November 1992, representatives of 93 nations meeting in Copenhagen agreed to phase out CFCs beginning January 1, 1996. Restriction on the use of HCFCs will start in 2004, with a complete phaseout by 2030.

In the earlier 1990s, R-11 was widely used for centrifugal chillers, R-12 for small and medium-size vapor compression systems, R-22 for all vapor compression systems, and CFC/HCFC blend R-502 for low-temperature vapor compression systems. Because of the phaseout of CFCs and BFCs before 1996 and HCFCs in the early years of the next century, alternative refrigerants have been developed to replace them:

- R-123 (an HCFC of ODP = 0.02) to replace R-11 is a short-term replacement that causes a slight reduction in capacity and efficiency. R-245ca (ODP = 0) may be the long-term alternative to R-11.
- R-134a (an HFC with ODP = 0) to replace R-12 in broad applications. R-134a is not miscible with mineral oil; therefore, a synthetic lubricant of polyolester is used.
- R-404A (R-125/R-134a/143a) and R-407C (R-32/R-125/R-134a) are both HFCs near azeotropic of ODP = 0. They are long-term alternatives to R-22. For R-407C, the composition of R-32 in the mixture is usually less than 30% so that the blend will not be flammable. R-407C has a drop of only 1 to 2% in capacity compared with R-22.
- R-507 (R-125/R-143a), an HFC's azeotropic with ODP = 0, is a long-term alternative to R-502. Synthetic polyolester lubricant oil will be used for R-507. There is no major performance difference between R-507 and R-502. R-402A (R-22/R-125/R-290), an HCFC's near azeotropic, is a short-term immediate replacement, and drop-in of R-502 requires minimum change of existing equipment except for reset of a higher condensing pressure.

Required Properties of Refrigerants

A refrigerant should not cause ozone depletion. A low global warming potential is required. Additional considerations for refrigerant selection are

1. *Safety*, including toxicity and flammability. ANSI/ASHRAE Standard 34-1992 classifies the *toxicity* of refrigerants as Class A and Class B. Class A refrigerants are of low toxicity. No toxicity was identified when their time-weighted average concentration was less than or equal to 400 ppm, to which workers can be exposed for an 8-hr workday and 40-hr work week without adverse effect. Class B refrigerants are of higher toxicity and produce evidence of toxicity.

ANSI/ASHRAE Standard 34-1982 classifies the *flammability* of refrigerants as Class 1, no flame propagation; Class 2, lower flammability; and Class 3, higher flammability.

The safety classification of refrigerants is based on the combination of toxicity and flammability: A1, A2, A3, B1, B2, and B3. R-134a and R-22 are in the A1 group, lower toxicity and nonflammable; R-123 in the B1 group, higher toxicity and nonflammable; and R-717 (ammonia) in the B2 group, higher toxicity and lower flammability.

2. *Effectiveness of refrigeration cycle.* High effectiveness is a desired property. The power consumed per ton of refrigeration produced, hp/ton or kW/ton, is an index for this assessment. Table 9.4.1 gives values for an ideal single-stage vapor compression cycle.
3. *Oil miscibility.* Refrigerant should be miscible with mineral lubricant oil because a mixture of refrigerant and oil helps to lubricate pistons and discharge valves, bearings, and other moving parts of a compressor. Oil should also be returned from the condenser and evaporator for continuous lubrication. R-22 is partially miscible. R-134a is hardly miscible with mineral oil; therefore, synthetic lubricant of polyolester will be used.
4. *Compressor displacement.* Compressor displacement per ton of refrigeration produced, in cfm/ton, directly affects the size of the positive displacement compressor and therefore its compactness. Ammonia R-717 requires the lowest compressor displacement (1.70 cfm/ton) and R-22 the second lowest (1.91 cfm/ton).
5. Desired properties:
 - Evaporating pressure p_{ev} should be higher than atmospheric. Then noncondensable gas will not leak into the system.
 - Lower condensing pressure for lighter construction of compressor, condenser, piping, etc.
 - A high thermal conductivity and therefore a high heat transfer coefficient in the evaporator and condenser.
 - Dielectric constant should be compatible with air when the refrigerant is in direct contact with motor windings in hermetic compressors.
 - An inert refrigerant that does not react chemically with material will avoid corrosion, erosion, or damage to system components. Halocarbons are compatible with all containment materials except magnesium alloys. Ammonia, in the presence of moisture, is corrosive to copper and brass.
 - Refrigerant leakage can be easily detected. Halide torch, electronic detector, and bubble detection are often used.

Ideal Single-Stage Vapor Compression Cycle

Refrigeration Process

A refrigeration process shows the change of the thermodynamic properties of the refrigerant and the energy and work transfer between the refrigerant and surroundings.

Energy and work transfer is expressed in British thermal units per hour, or Btu/hr. Another unit in wide use is ton of refrigeration, or ton. A ton = 12,000 Btu/hr of heat removed; i.e., 1 ton of ice melting in 24 hr = 12,000 Btu/hr.

Refrigeration Cycles

When a refrigerant undergoes a series of processes like evaporation, compression, condensation, throttling, and expansion, absorbing heat from a low-temperature source and rejecting it to a higher temperature sink, it is said to have undergone a refrigeration cycle. If its final state is equal to its initial state, it is a *closed cycle*; if the final state does not equal the initial state, it is an *open cycle*. Vapor compression refrigeration cycles can be classified as single stage, multistage, compound, and cascade cycles.

A *pressure-enthalpy diagram* or *p-h diagram* is often used to calculate the energy transfer and to analyze the performance of a refrigeration cycle, as shown in Figure 9.4.1. In a *p-h* diagram, pressure p , in psia or psig logarithmic scale, is the ordinate, and enthalpy h , in Btu/lb, is the abscissa. The saturated liquid and saturated vapor line encloses a two-phase region in which vapor and liquid coexist. The two-phase region separates the subcooling liquid and superheated vapor regions. The constant-temperature

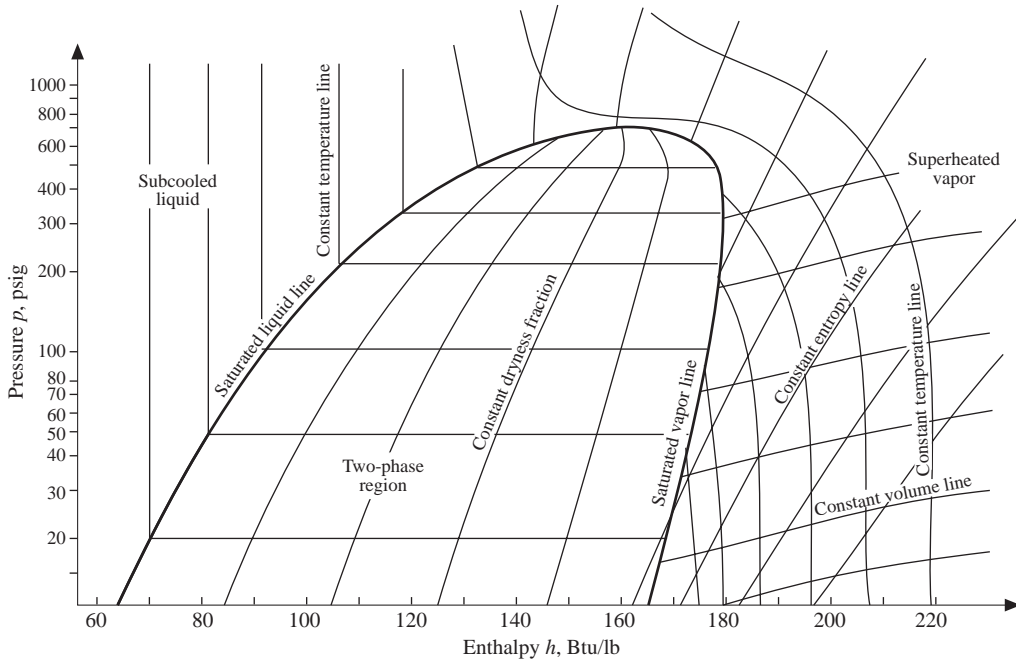

FIGURE 9.4.1 Skeleton of pressure-enthalpy diagram for R-22.

line is nearly vertical in the subcooling region, horizontal in the two-phase region, and curved down sharply in the superheated region.

In the two-phase region, a given saturated pressure determines the saturated temperature and vice versa. The constant-entropy line is curved upward to the right-hand side in the superheated region. Each kind of refrigerant has its own p - h diagram.

Refrigeration Processes in an Ideal Single-Stage Cycle

An *ideal cycle* has isentropic compression, and pressure losses in the pipeline, valves, and other components are neglected. All refrigeration cycles covered in this section are ideal. Single stage means a single stage of compression.

There are four refrigeration processes in an ideal single-stage vapor compression cycle, as shown in Figure 9.4.2(a) and (b):

1. Isothermal evaporation process 4–1 — The refrigerant evaporates completely in the evaporator and produces refrigeration effect q_{rf} , in Btu/lb:

$$q_{rf} = (h_1 - h_4) \tag{9.4.1}$$

where h_1, h_4 = enthalpy of refrigerant at state points 1 and 4, respectively, Btu/lb.

2. Isentropic compression process 1–2 — Vapor refrigerant is extracted by the compressor and compressed isentropically from point 1 to 2. The work input to the compressor W_{in} , in Btu/lb, is

$$W_{in} = (h_2 - h_1) \tag{9.4.2}$$

where h_2 = enthalpy of refrigerant at state point 2, Btu/lb.

The greater the difference in temperature/pressure between the condensing pressure p_{con} and evaporating pressure p_{ev} , the higher will be the work input to the compressor.

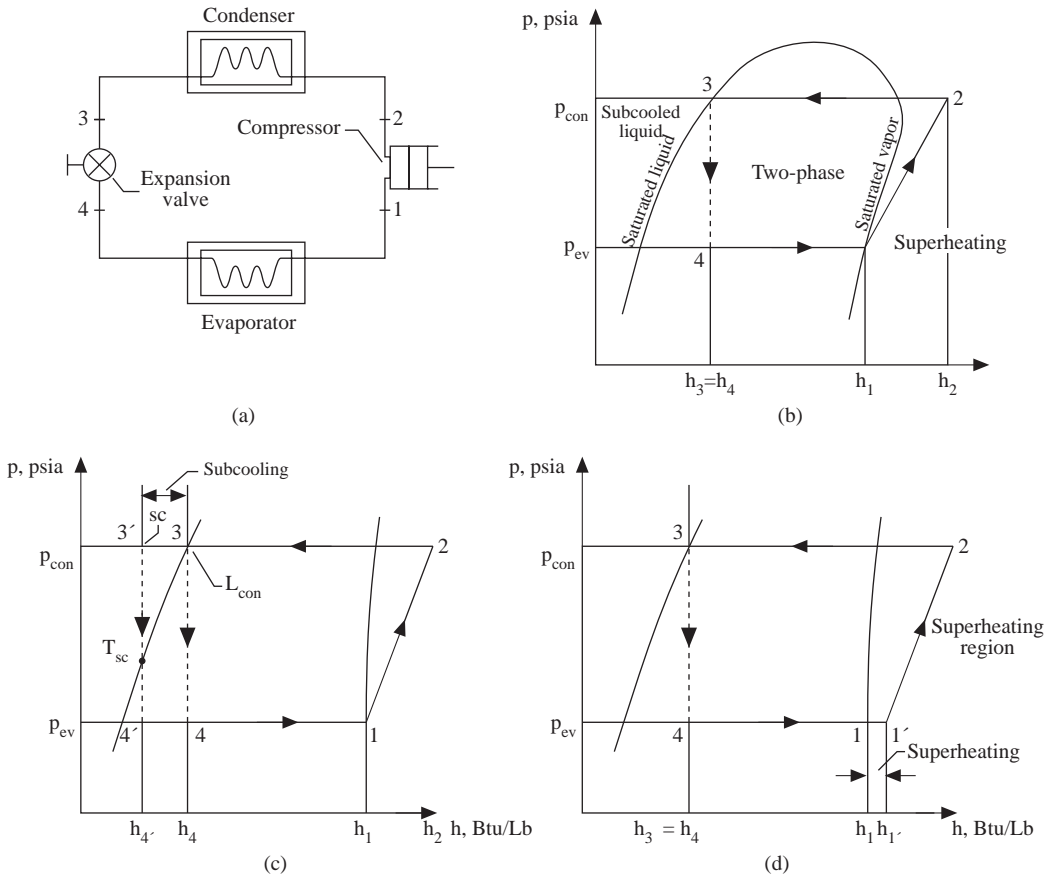

FIGURE 9.4.2 A single-stage ideal vapor compression refrigeration cycle: (a) schematic diagram, (b) p - h diagram, (c) subcooling, and (d) superheating.

3. Isothermal condensation process 2–3 — Hot gaseous refrigerant discharged from the compressor is condensed in the condenser into liquid, and the latent heat of condensation is rejected to the condenser water or ambient air. The heat rejection during condensation, q_{2-3} , in Btu/lb, is

$$-q_{2-3} = (h_2 - h_3) \tag{9.4.3}$$

where h_3 = enthalpy of refrigerant at state point 3, Btu/lb.

4. Throttling process 3–4 — Liquid refrigerant flows through a throttling device (e.g., an expansion valve, a capillary tube, or orifices) and its pressure is reduced to the evaporating pressure. A portion of the liquid flashes into vapor and enters the evaporator. This is the only irreversible process in the ideal cycle, usually represented by a dotted line. For a throttling process, assuming that the heat gain from the surroundings is negligible:

$$h_3 = h_4 \tag{9.4.4}$$

The mass flow rate of refrigerant \dot{m}_r , in lb/min, is

$$\dot{m}_r = q_{rc} / 60q_{rf} \tag{9.4.5}$$

where q_{rc} = refrigeration capacity of the system, Btu/hr.

The ideal single-stage vapor compression refrigeration cycle on a p - h diagram is divided into two pressure regions: high pressure (p_{con}) and low pressure (p_{ev}).

Coefficient of Performance of Refrigeration Cycle

The *coefficient of performance* (COP) is a dimensionless index used to indicate the performance of a thermodynamic cycle or thermal system. The magnitude of COP can be greater than 1.

- If a *refrigerator* is used to produce a refrigeration effect, COP_{ref} is

$$COP_{ref} = q_{rf} / W_{in} \quad (9.4.6)$$

- If a *heat pump* is used to produce a useful heating effect, its performance denoted by COP_{hp} is

$$COP_{hp} = q_{2-3} / W_{in} \quad (9.4.7)$$

- For a heat recovery system when both refrigeration and heating effects are produced, the COP_{hr} is denoted by the ratio of the sum of the absolute values of q_{rf} and q_{2-3} to the work input, or

$$COP_{hr} = (|q_{rf}| + |q_{2-3}|) / W_{in} \quad (9.4.8)$$

Subcooling and Superheating

Condensed liquid is often subcooled to a temperature lower than the saturated temperature corresponding to the condensing pressure p_{con} , in psia or psig, as shown in [Figure 9.4.2\(c\)](#). *Subcooling* increases the refrigeration effect to $q_{rf,sc}$ as shown in [Figure 9.4.2\(c\)](#):

$$q_{rf,sc} = (h_{4'} - h_1) > (h_4 - h_1) \quad (9.4.9)$$

The enthalpy of subcooled liquid refrigerant h_{sc} approximately equals the enthalpy of the saturated liquid refrigerant at subcooled temperature $h_{s,sc}$, both in Btu/lb:

$$h_{sc} = h_{3'} = h_{4'} = h_{l,con} - c_{pr}(T_{con} - T_{sc}) \approx h_{s,sc} \quad (9.4.10)$$

where $h_{3'}$, $h_{4'}$ = enthalpy of liquid refrigerant at state points 3' and 4' respectively, Btu/lb

$h_{l,con}$ = enthalpy of saturated liquid at condensing temperature, Btu/lb

c_{pr} = specific heat of liquid refrigerant at constant pressure, Btu/lb °F

T_{con} = condensing temperature or saturated temperature of liquid refrigerant at condensing pressure, °F

T_{sc} = temperature of subcooled liquid refrigerant, °F

The purpose of *superheating* is to prevent liquid refrigerant flooding back into the compressor and causing slugging damage as shown in [Figure 9.4.2\(d\)](#). The degree of superheating depends mainly on the types of refrigerant feed, construction of the suction line, and type of compressor. The state point of vapor refrigerant after superheating of an ideal system must be at the evaporating pressure with a specific degree of superheat and can be plotted on a p - h diagram for various refrigerants.

Refrigeration Cycle of Two-Stage Compound Systems with a Flash Cooler

A *multistage system* employs more than one compression stage. Multistage vapor compression systems are classified as compound systems and cascade systems. A *compound system* consists of two or more

compression stages connected in series. It may have one high-stage compressor (higher pressure) and one low-stage compressor (lower pressure), several compressors connected in series, or two or more impellers connected internally in series and driven by the same motor.

The *compression ratio* R_{com} is defined as the ratio of discharge pressure p_{dis} to the suction pressure at the compressor inlet p_{suc} :

$$R_{com} = p_{dis}/p_{suc} \tag{9.4.11}$$

Compared to a single-stage system, a multistage has a smaller compression ratio and higher compression efficiency for each stage of compression, greater refrigeration effect, lower discharge temperature at the high-stage compressor, and greater flexibility. At the same time, a multistage system has a higher initial cost and more complicated construction.

The pressure between the discharge pressure of the high-stage compressor and the suction pressure of the low-stage compressor of a multistage system is called *interstage pressure* p_i , in psia. Interstage pressure for a two-stage system is usually determined so that the compression ratios are nearly equal between two stages for a higher COP. Then the interstage pressure is

$$p_i = \sqrt{(p_{con}p_{ev})} \tag{9.4.12}$$

where p_{con} , p_{ev} = condensing and evaporating pressures, psia.

For a multistage system of n stages, then, the compression ratio of each stage is

$$R_{com} = (p_{con}/p_{suc})^{1/n} \tag{9.4.13}$$

Figure 9.4.3(a) shows a schematic diagram and Figure 9.4.3(b) the refrigeration cycle of a two-stage compound system with a flash cooler. A *flash cooler*, sometimes called an economizer, is used to subcool the liquid refrigerant to the saturated temperature corresponding to the interstage pressure by vaporizing a portion of the liquid refrigerant in the flash cooler.

Based on the principle of heat balance, the fraction of evaporated refrigerant, x , or quality of the mixture in the flash cooler is

$$x = (h_{5'} - h_8)/(h_7 - h_8) \tag{9.4.14}$$

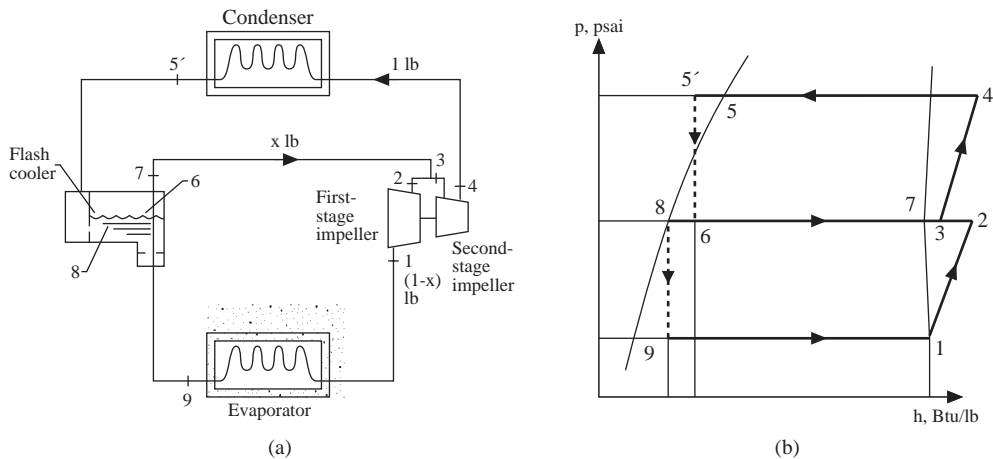

FIGURE 9.4.3 Two-stage compound system with a flash cooler: (a) schematic diagram and (b) refrigeration cycle.

where h_5, h_7, h_8 = enthalpy of the refrigerant at state points 5', 7, and 8, respectively, Btu/lb. The coefficient of performance of the refrigeration cycle of a two-stage compound system with a flash cooler, COP_{ref} , is given as

$$COP_{ref} = q_{rf}/W_{in} = (1-x)(h_1 - h_9) / [(1-x)(h_2 - h_1) + (h_4 - h_3)] \tag{9.4.15}$$

where h_1, h_2, h_3, h_4, h_9 = enthalpy of refrigerant at state points 1, 2, 3, 4, and 9, respectively, Btu/lb. The mass flow rate of refrigerant flowing through the condenser, \dot{m}_r , in lb/min, can be calculated as

$$\dot{m}_r = q_{rc} / 60q_{rf} \tag{9.4.16}$$

Because a portion of liquid refrigerant is flashed into vapor in the flash cooler and goes directly to the second-stage impeller inlet, less refrigerant is compressed in the first-stage impeller. In addition, the liquid refrigerant in the flash cooler is cooled to the saturated temperature corresponding to the interstage temperature before entering the evaporator, which significantly increases the refrigeration effect of this compound system. Two-stage compound systems with flash coolers are widely used in large central air-conditioning systems.

Cascade System Characteristics

A *cascade system* consists of two independently operated single-stage refrigeration systems: a lower system that maintains a lower evaporating temperature and produces a refrigeration effect and a higher system that operates at a higher evaporating temperature as shown in Figure 9.4.4(a) and (b). These two separate systems are connected by a *cascade condenser* in which the heat released by the condenser in the lower system is extracted by the evaporator in the higher system.

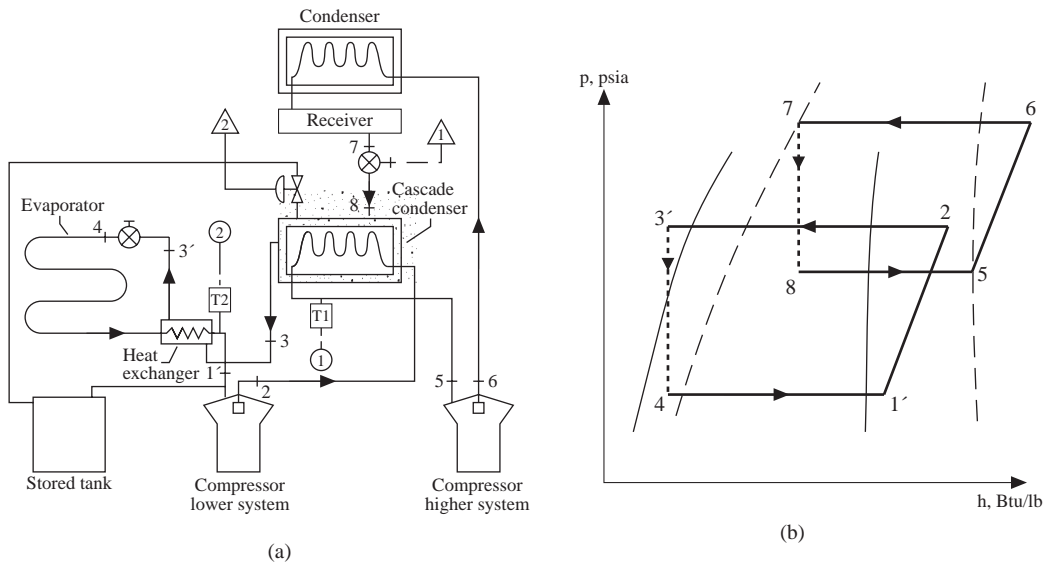

FIGURE 9.4.4 Cascade system: (a) schematic diagram and (b) refrigeration cycle.

A heat exchanger is often used between the liquid refrigerant from the condenser and the vapor refrigerant leaving the evaporator of the lower system. When the system is shut down in summer, a relief valve connected to a stored tank should be used to relieve the higher pressure of refrigerant at the higher storage temperature.

The main advantages of a cascade system compared with a compound system are that different refrigerants, oils, and equipment can be used for the lower and higher systems. Disadvantages are the overlap of the condensing temperature of the lower system and the evaporating temperature of the higher system because of the heat transfer in the cascade condenser and a more complicated system.

The refrigeration effect q_{rf} of the cascade system is

$$q_{\text{rf}} = (h_1 - h_4) \quad (9.4.17)$$

where h_1, h_4 = enthalpy of the refrigerant leaving and entering the evaporator of the lower system, Btu/lb. The total work input to the compressors in both higher and lower systems W_{in} , in Btu/lb, can be calculated as

$$W_{\text{in}} = (h_2 - h_{1'}) + \dot{m}_h (h_6 - h_5) / \dot{m}_l \quad (9.4.18)$$

where h_2 = enthalpy of refrigerant discharged from the compressor of the lower system
 $h_{1'}$ = enthalpy of the vapor refrigerant leaving the heat exchanger
 h_6, h_5 = enthalpy of the refrigerant leaving and entering the high-stage compressor
 \dot{m}_h, \dot{m}_l = mass flow rate of the refrigerant of the higher and lower systems, respectively

The coefficient of performance of a cascade system COP_{ref} is

$$\text{COP}_{\text{ref}} = q_{\text{rf}} / W_{\text{in}} = \dot{m}_l (h_1 - h_4) / \left[\dot{m}_l (h_2 - h_{1'}) + \dot{m}_h (h_6 - h_5) \right] \quad (9.4.19)$$

9.7 Air Handling Units and Packaged Units

Terminals and Air Handling Units

A *terminal unit*, or *terminal*, is a device or equipment installed directly in or above the conditioned space to cool, heat, filter, and mix outdoor air with recirculating air. Fan-coil units, VAV boxes, fan-powered VAV boxes, etc. are all terminals.

An *air handling unit* (AHU) handles and conditions the air, controls it to a required state, and provides motive force to transport it. An AHU is the primary equipment of the air system in a central air-conditioning system. The basic components of an AHU include a supply fan with a fan motor, a water cooling coil, filters, a mixing box except in a makeup AHU unit, dampers, controls, and an outer casing. A return or relief fan, heating coil(s), and humidifier are optional depending on requirements. The supply volume flow rate of AHUs varies from 2000 to about 60,000 cfm.

AHUs are classified into the followings groups according to their structure and location.

Horizontal or Vertical Units

Horizontal AHUs have their fan, coils, and filters installed at the same level as shown in Figure 9.7.1(a). They need more space and are usually for large units. In *vertical units*, as shown in Figure 9.7.1(b), the supply fan is installed at a level higher than coils and filters. They are often comparatively smaller than horizontal units.

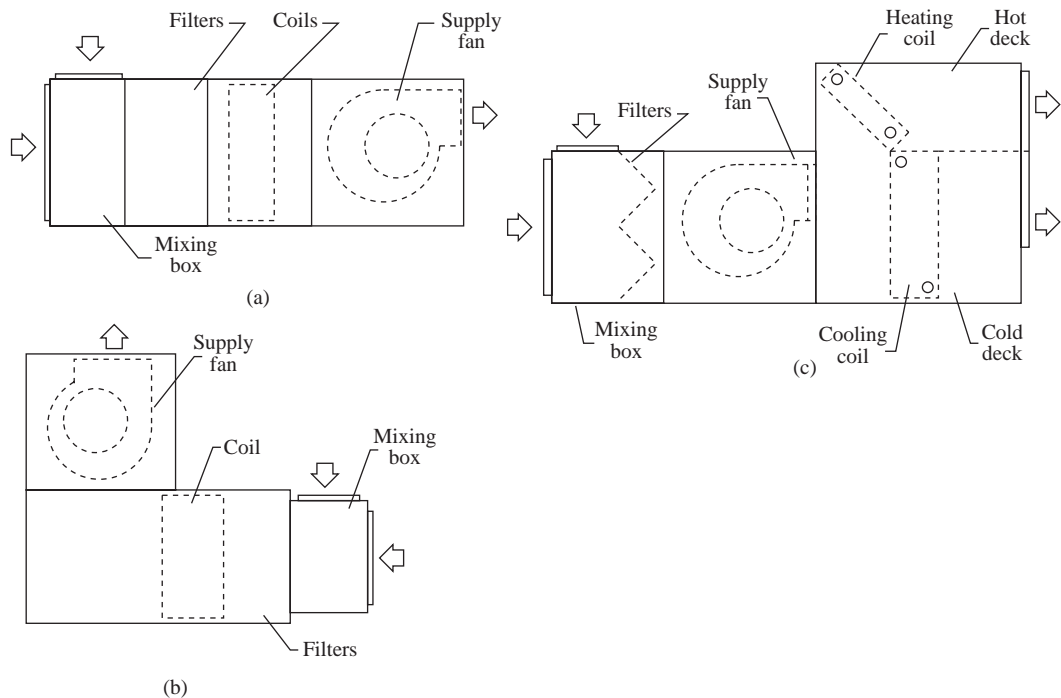

FIGURE 9.7.1 Type of air handling units: (a) horizontal draw-through unit, (b) vertical draw-through unit, and (c) multizone blow-through unit.

Draw-Through or Blow-Through Units

In a *draw-through unit*, as shown in Figure 9.7.1(a), the supply fan is located downstream of the coils. Air is evenly distributed over the coil section, and the fan discharge can easily be connected to a supply duct of nearly the same air velocity. In a *blow-through unit*, as shown in Figure 9.7.1(c), the supply fan

is located upstream of the coils. It usually has hot and cold decks with discharge dampers connected to warm and cold ducts, respectively.

Factory-Fabricated and Field Built-Up Units

Factory-fabricated units are standard in construction and layout, low in cost, of higher quality, and fast in installation. *Field built-up units* or *custom-built units* are more flexible in construction, layout, and dimensions than factory-built standardized units.

Rooftop and Indoor Units

A *rooftop AHU*, sometimes called a penthouse unit, is installed on the roof and will be completely weatherproof. An *indoor AHU* is usually located in a fan room or ceiling and hung like small AHU units.

Make-Up Air and Recirculating Units

A *make-up AHU*, also called a primary-air unit, is used to condition outdoor air entirely. It is a once-through unit. There is no return air and mixing box. *Recirculating units* can have 100% outdoor air intake or mixing of outdoor air and recirculating air.

Packaged Units

A *packaged unit* (PU) is a self-contained air conditioner. It conditions the air and provides it with motive force and is equipped with its own heating and cooling sources. The packaged unit is the primary equipment in a packaged air-conditioning system and is always equipped with a DX coil for cooling, unlike an AHU. R-22, R-134a, and others are used as refrigerants in packaged units. The portion that handles air in a packaged unit is called an *air handler* to distinguish it from an AHU. Like an AHU, an indoor air handler has an indoor fan, a DX coil (indoor coil), filters, dampers, and controls. Packaged units can be classified according to their place of installation: rooftop, indoor, and split packaged units.

Rooftop Packaged Units

A *rooftop packaged unit* is mounted on the roof of the conditioned space as shown in [Figure 9.7.2](#). From the types of heating/cooling sources provided, rooftop units can be subdivided into:

- Gas/electric rooftop packaged unit, in which heating is provided by gas furnace and cooling by electric power-driven compressors.
- Electric/electric rooftop packaged unit, in which electric heating and electric power-driven compressors provide heating and cooling.
- Rooftop packaged heat pump, in which both heating and cooling are provided by the same refrigeration system using a four-way reversing valve (heat pump) in which the refrigeration flow changes when cooling mode is changed to heating mode and vice versa. Auxiliary electric heating is provided if necessary.

Rooftop packaged units are single packaged units. Their cooling capacity may vary from 3 to 220 tons with a corresponding volume flow rate of 1200 to 80,000 cfm. Rooftop packaged units are the most widely used packaged units.

Indoor Packaged Units

An *indoor packaged unit* is also a single packaged and factory-fabricated unit. It is usually installed in a fan room or a machinery room. A small or medium-sized indoor packaged unit could be floor mounted directly inside the conditioned space with or without ductwork. The cooling capacity of an indoor packaged unit may vary from 3 to 100 tons and volume flow rate from 1200 to 40,000 cfm.

Indoor packaged units are also subdivided into:

- Indoor packaged cooling units

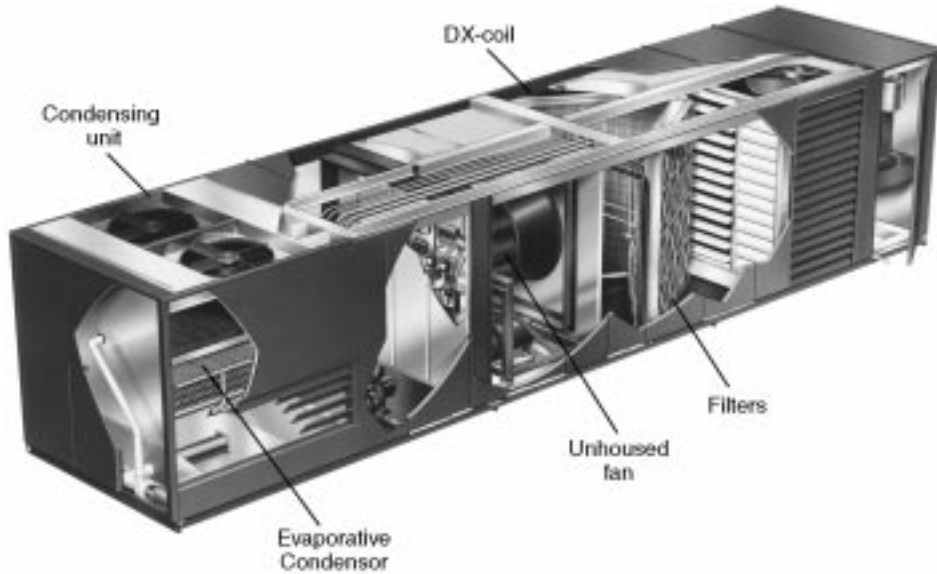

FIGURE 9.7.2 A cut view of a rooftop package unit. (Source: Mammoth, Inc. Reprinted by permission.)

- Indoor packaged cooling/heating units, in which heating may be provided from a hot water heating coil, a steam heating coil, and electric heating
- Indoor packaged heat pumps

Indoor packaged units have either an air-cooled condenser on the rooftop or a shell-and-tube or double-tube water-cooled condenser inside the unit.

Split Packaged Units

A *split packaged unit* consists of two separate pieces of equipment: an indoor air handler and an outdoor condensing unit. The indoor air handler is often installed in the fan room. Small air handlers can be ceiling hung. The condensing unit is usually located outdoors, on a rooftop or podium or on the ground.

A split packaged unit has its compressors and condenser in its outdoor condensing unit, whereas an indoor packaged unit usually has its compressors indoors. The cooling capacity of split packaged units varies from 3 to 75 tons and the volume flow rate from 1200 to 30,000 cfm.

Rating Conditions and Minimum Performance

Air Conditioning and Refrigeration Institute (ARI) Standards and ASHRAE/IES Standard 90.1-1989 specified the following rating indices:

- Energy efficiency ratio (EER) is the ratio of equipment cooling capacity, in Btu/hr, to the electric input, in W, under rating conditions.
- SEER is the seasonal EER, or EER during the normal annual usage period.
- IPLV is the integrated part-load value. It is the summarized single index of part-load efficiency of PUs based on weighted operations at several load conditions.
- HSPF is the heating seasonal performance factor. It is the total heating output of a heat pump during its annual usage period for heating, in Btu, divided by the total electric energy input to the heat pump during the same period, in watt-hours.

According to ARI standards, the minimum performance for air-cooled, electrically operated single packaged units is

	q_{rc} (Btu/hr)	T_o (°F)	EER	T_o (°F)	IPLV
Air-cooled	<65,000	95	9.5		
	$65,000 \leq q_{rc} < 135,000$	95	8.9	80	8.3
	$135,000 \leq q_{rc} < 760,000$		8.5		7.5

For water- and evaporatively cooled packaged units including heat pumps, refer to ASHRAE/IES Standard 90.1-1989 and also ARI Standards.

Coils

Coils, Fins, and Water Circuits

Coils are indirect contact heat exchangers. Heat transfer or heat and mass transfer takes place between conditioned air flowing over the coil and water, refrigerant, steam, or brine inside the coil for cooling, heating, dehumidifying, or cooling/dehumidifying. Chilled water, brine, and refrigerants that are used to cool and dehumidify the air are called *coolants*. Coils consist of tubes and external fins arranged in rows along the air flow to increase the contact surface area. Tubes are usually made of copper; in steam coils they are sometimes made of steel or even stainless steel. Copper tubes are staggered in 2, 3, 4, 6, 8, or up to 10 rows.

Fins are extended surfaces often called *secondary surfaces* to distinguish them from the *primary surfaces*, which are the outer surfaces of the tubes. Fins are often made from aluminum, with a thickness $F_t = 0.005$ to 0.008 in., typically 0.006 in. Copper, steel, or sometimes stainless steel fins are also used. Fins are often in the form of continuous plate fins, corrugated plate fins to increase heat transfer, crimped spiral or smooth spiral fins that may be extruded from the aluminum tubes, and spine pipes, which are shaved from the parent aluminum tubes. Corrugated plate fins are most widely used.

Fin spacing S_f is the distance between two fins. *Fin density* is often expressed in fins per inch and usually varies from 8 to 18 fins/in.

In a water cooling coil, *water circuits* or *tube feeds* determine the number of water flow passages. The greater the finned width, the higher the number of water circuits and water flow passages.

Direct Expansion (DX) Coil

In a *direct expansion coil*, the refrigerant, R-22, R-134a, or others, is evaporated and expanded directly inside the tubes to cool and dehumidify the air as shown in Figure 9.7.3(a). Refrigerant is fed to a distributor and is then evenly distributed to various copper tube circuits typically 0.375 in. in diameter. Fin density is usually 12 to 18 fins/in. and a four-row DX coil is often used. On the inner surface of the copper tubes, microfins, typically at 60 fins/in. and a height of 0.008 in., are widely used to enhance the boiling heat transfer.

Air and refrigerant flow is often arranged in a combination of counterflow and cross flow and the discharge header is often located on the air-entering side. Refrigerant distribution and loading in various circuits are critical to the coil's performance. Vaporized vapor refrigerant is superheated 10 to 20°F in order to prevent any liquid refrigerant from flooding back to the reciprocating compressors and damaging them. Finally, the vapor refrigerant is discharged to the suction line through the header.

For comfort air-conditioning systems, the evaporating temperature of refrigerant T_{ev} inside the tubes of a DX coil is usually between 37 and 50°F. At such a temperature, the surface temperature of the coil is often lower than the dew point of the entering air. Condensation occurs at the coil's outside surface, and the coil becomes a wet coil. A condensate *drain pan* is necessary for each vertically banked DX coil, and a trap should be installed to overcome the negative pressure difference between the air in the coil section and the ambient air.

Face velocity of the DX coil v_a , in fpm, is closely related to the blow-off of the water droplets of the condensate, the heat transfer coefficients, the air-side pressure drop, and the size of the air system. For corrugated fins, the upper limit is 600 fpm, with an air-side pressure drop of 0.20 to 0.30 in. WG/row.

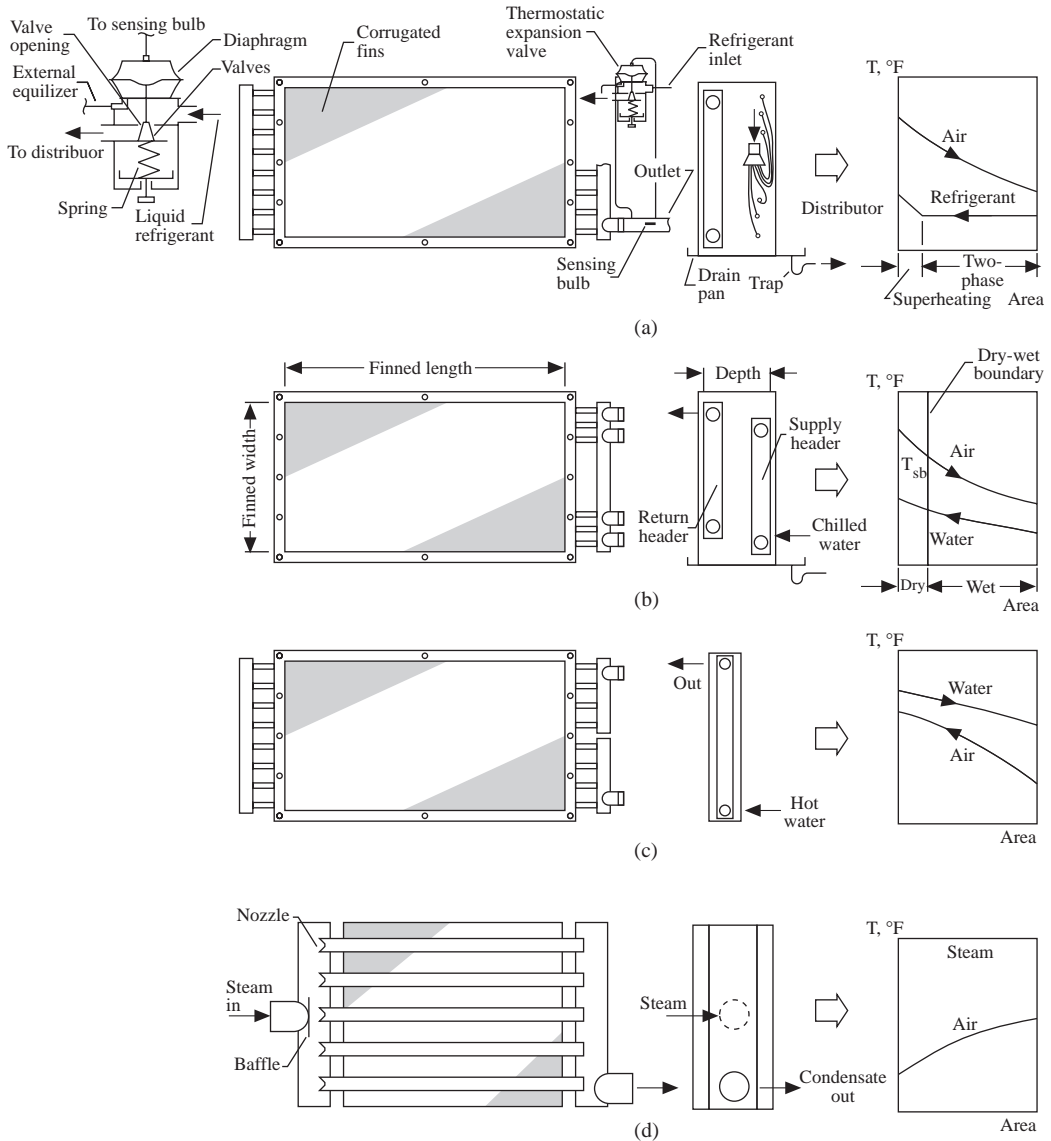

FIGURE 9.7.3 Types of coils: (a) direct expansion coil, (b) water cooling coil, (c) water heating coil, and (d) steam heating coil.

A large DX coil is often divided into two refrigerant sections, each with its own expansion valve, distributor, and discharge header.

For a packaged unit of a specific model, size, face velocity and condition of entering air and outdoor air, the DX coil’s cooling capacities in nominal tons, number of rows, and fin density are all fixed values.

Water Cooling Coils — Dry-Wet Coils

In a water cooling coil, chilled water at a temperature of 40 to 50°F, brine, or glycol-water at a temperature of 34 to 40°F during cold air distribution enters the coil. The temperature of chilled water, brine, or glycol-water is usually raised 12 to 24°F before it leaves the water cooling coil.

The water tubes are usually copper tubes of 1/2 to 5/8 in. diameter with a tube wall thickness of 0.01 to 0.02 in. They are spaced at a center-to-center distance of 0.75 to 1.25 in. longitudinally and 1 to 1.5

in. transversely. These tubes may be staggered in 2, 3, 4, 6, 8, or 10 rows. Chilled water coils are often operated at a pressure of 175 to 300 psig.

As in a DX coil, the air flow and water flow are in a combination of counterflow and cross flow. The outer surface of a chilled water cooling coil at the air entering side T_{se} is often greater than the dew point of the entering air T_{ae}'' , or $T_{se} > T_{ae}''$. The outer surface temperature of coil at the air leaving side T_{sl} may be smaller than T_{ae}'' , or $T_{sl} < T_{ae}''$. Then the water cooling coil becomes a dry-wet coil with part of the dry surface on the air entering side and part of the wet surface on the air leaving side. A *dry-wet boundary* divides the dry and wet surfaces. At the boundary, the tube outer surface temperature $T_{sb} = T_{ae}''$ as shown in [Figure 9.7.3\(b\)](#). A condensate drain pan is necessary for a dry-wet coil.

A water cooling coil is selected from the manufacturer's selection program or from its catalog at (1) a dry and wet bulb of entering air, such as 80°F dry bulb and 67°F wet bulb; (2) an entering water temperature, such as 44 or 45°F; (3) a water temperature rise between 10 and 24°F; and (4) a coil face velocity between 400 and 600 fpm. The number of rows and fins per inch is varied to meet the required sensible and cooling coil load, in Btu/hr.

Water Cooling Coil-Dry Coil

When the temperature of chilled water entering the water cooling coil $T_{we} \geq T_{ae}''$, condensation will not occur on the outer surface of the coil. This coil becomes a sensible cooling-dry coil, and the humidity ratio of the conditioned air w_a remains constant during the sensible cooling process.

The construction of a sensible cooling-dry coil, such as material, tube diameter, number of rows, fin density, and fin thickness, is similar to that of a dry-wet coil except that a dry coil always has a poorer surface heat transfer coefficient than a wet coil, and therefore a greater coil surface area is needed; the maximum face velocity of a dry coil can be raised to $v_a \leq 800$ fpm; and the coil's outer surface is less polluted. The effectiveness of a dry coil ϵ_{dry} is usually 0.55 to 0.7.

Water Heating Coil

The construction of a water heating coil is similar to that of a water cooling coil except that in water heating coils hot water is supplied instead of chilled water and there are usually fewer rows, only 2, 3, and 4 rows, than in water cooling coils. Hot water pressure in water heating coils is often rated at 175 to 300 psig at a temperature up to 250°F. [Figure 9.7.3\(c\)](#) shows a water heating coil.

Steam Heating Coil

In a steam heating coil, latent heat of condensation is released when steam is condensed into liquid to heat the air flowing over the coil, as shown in [Figure 9.7.3\(d\)](#). Steam enters at one end of the coil, and the condensate comes out from the opposite end. For more even distribution, a baffle plate is often installed after the steam inlet. Steam heating coils are usually made of copper, steel, or sometimes stainless steel.

For a steam coil, the coil core inside the casing should expand or contract freely. The coil core is also pitched toward the outlet to facilitate condensate drainage. Steam heating coils are generally rated at 100 to 200 psig at 400°F.

Coil Accessories and Servicing

Coil accessories include air vents, drain valves, isolation valves, pressure relief valves, flow metering valves, balancing valves, thermometers, pressure gauge taps, condensate drain taps, and even distribution baffles. They are employed depending on the size of the system and operating and servicing requirements.

Coil cleanliness is important for proper operation. If a medium-efficiency air filter is installed upstream of the coil, dirt accumulation is often not a problem. If a low-efficiency filter is employed, dirt accumulation may block the air passage and significantly increase the pressure drop across the coil. Coils should normally be inspected and cleaned every 3 months in urban areas when low-efficiency filters are used. Drain pans should be cleaned every month to prevent buildup of bacteria and microorganisms.

Coil Freeze-Up Protection

Improper mixing of outdoor air and recirculating air in the mixing box of an AHU or PU may cause coil freeze-up when the outdoor air temperature is below 32°F. Outdoor air should be guided by a baffle plate and flow in an opposite direction to the recirculating air stream so that they can be thoroughly mixed without stratification.

Run the chilled water pump for the idle coil with a water velocity of 2.5 ft/sec, so that the cooling coil will not freeze when the air temperature drops to 32°F. A better method is to drain the water completely. For a hot water coil, it is better to reset the hot water temperature at part-load operation instead of running the system intermittently. A steam heating coil with inner distributor tubes and outer finned heating tubes provides better protection against freeze-up.

Air Filters

Air Cleaning and Filtration

Air cleaning is the process of removing airborne particles from the air. Air cleaning can be classified into air filtration and industrial air cleaning. Industrial air cleaning involves the removal of dust and gaseous contaminants from manufacturing processes as well as from the space air, exhaust air, and flue gas for air pollution control. In this section, only air filtration is covered.

Air filtration involves the removal of airborne particles presented in the conditioned air. Most of the airborne particles removed by air filtration are smaller than 1 μm , and the concentration of these particles in the airstream seldom exceeds 2 mg/m^3 . The purpose of air filtration is to benefit the health and comfort of the occupants as well as meet the cleanliness requirements of the working area in industrial buildings.

An *air filter* is a kind of air cleaner that is installed in AHUs, PUs, and other equipment to filter the conditioned air by inertial impaction or interception and to diffuse and settle fine dust particles on the fibrous medium. The filter medium is the fabricated material that performs air filtration.

Operating performance of air filters is indicated by their:

- *Efficiency* or effectiveness of dust removal
- *Dust holding capacity* m_{dust} , which is the amount of dust held in the air filter, in grains/ft²
- *Initial pressure drop* when the filter is clean Δp_{fi} and *final pressure drop* Δp_{ff} when the filter's m_{dust} is maximum, both in in. WG
- *Service life*, which is the operating period between Δp_{fi} and Δp_{ff}

Air filters in AHUs and PUs can be classified into low-, medium-, and high-efficiency filters and carbon activated filters.

Test Methods

The performance of air filters is usually tested in a test unit that consists of a fan, a test duct, the tested filter, two samplers, a vacuum pump, and other instruments. Three test methods with their own test dusts and procedures are used for the testing of low-, medium-, and high-efficiency air filters.

The *weight arrestance test* is used for low-efficiency air filters to assess their ability to remove coarse dusts. Standard synthetic dusts that are considerably coarser than atmospheric dust are fed to the test unit. By measuring the weight of dust fed and the weight gain due to the dust collected on the membrane of the sampler after the tested filter, the arrestance can be calculated.

The *atmospheric dust spot efficiency test* is used for medium-efficiency air filters to assess their ability to remove atmospheric dusts. *Atmospheric dusts* are dusts contained in the outdoor air, the outdoor atmosphere. Approximately 99% of atmospheric dusts are dust particles $<0.3 \mu\text{m}$ that make up 10% of the total weight; 0.1% of atmospheric dusts is particles $>1 \mu\text{m}$ that make up 70% of the total weight.

Untreated atmospheric dusts are fed to the test unit. Air samples taken before and after the tested filter are drawn through from identical fiber filter-paper targets. By measuring the light transmission of these discolored white filter papers, the efficiency of the filter can be calculated. Similar atmospheric

dust spot test procedures have been specified by American Filter Institute (AFI), ASHRAE Standard 52.1, and former National Bureau of Standards (NBS).

The *DOP penetration and efficiency test* or simply *DOP test* is used to assess high-efficiency filters removing dusts particles of $0.18\ \mu\text{m}$. According to U.S. Military Standard MIL-STD-282 (1956), a smoke cloud of uniform dioctyl phthalate (DOP) droplets $0.18\ \mu\text{m}$ in diameter, generated from the condensation of the DOP vapor, is fed to the test unit. By measuring the concentration of these particles in the air stream upstream and downstream of the tested filter using an electronic particle counter or laser spectrometer, the penetration and efficiency of the air filter can be calculated.

Low-Efficiency Air Filters

ASHRAE weight arrestance for low-efficiency filters is between 60 and 95%, and ASHRAE dust spot efficiency for low-efficiency filters is less than 20%. These filters are usually in panels as shown in Figure 9.7.4(a). Their framework is typically 20×20 in. or 24×24 in. Their thickness varies from 1 to 4 in.

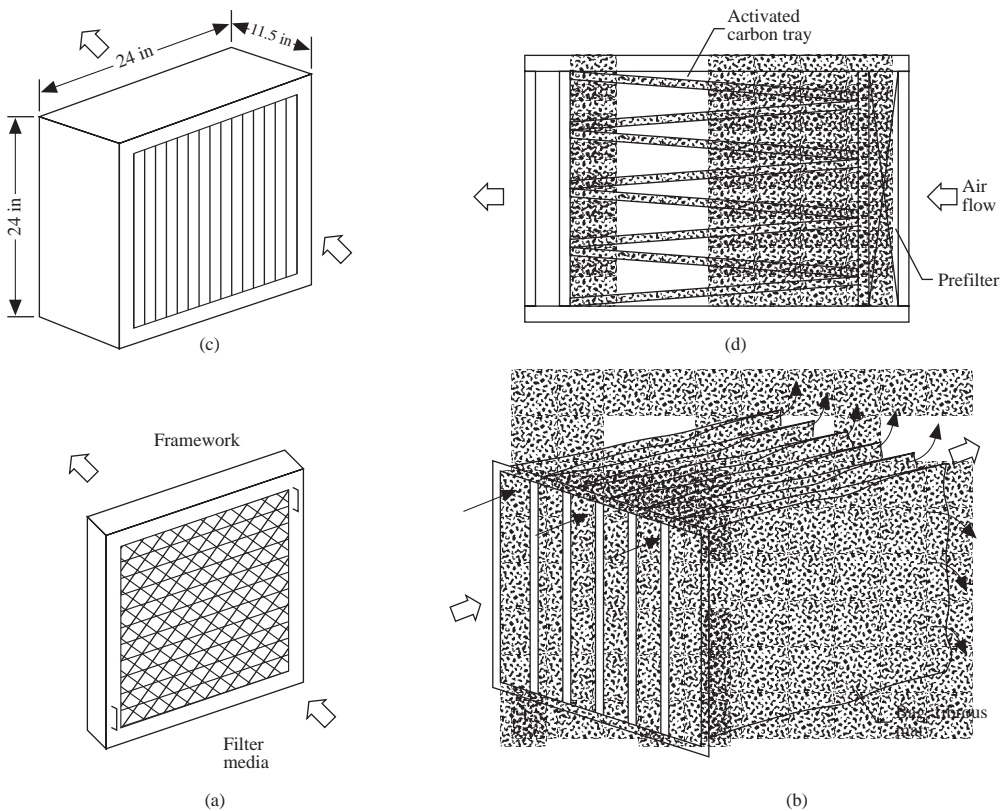

FIGURE 9.7.4 Various types of air filters: (a) low efficiency, (b) medium efficiency, (c) HEPA and ULPA filters, and (d) activated carbon filter.

For low-efficiency filters, the filter media are often made of materials such as

- Corrugated wire mesh and screen strips coated with oil, which act as adhesives to enhance dust removal. Detergents may be used to wash off dusts so that the filter media can be cleaned and reused — they are therefore called *viscous and reusable*.
- Synthetic fibers (nylon, terylene) and polyurethane foam can be washed, cleaned, and reused if required — *dry and reusable*.

- Glass fiber mats with fiber diameter greater than 10 μm . The filter medium is discarded when its final pressure drop is reached — *dry and disposable*. The face velocity of the panel filter is usually between 300 and 600 fpm. The initial pressure drop varies from 0.05 to 0.25 in. WG and the final pressure drop from 0.2 to 0.5 in. WG.

Medium-Efficiency Air Filters

These air filters have an ASHRAE dust spot efficiency usually between 20 and 95%. Filter media of medium-efficiency filters are usually made of glass fiber mat with a fiber diameter of 10 to 1 μm using nylon fibers to join them together. They are usually dry and disposable. In addition:

- As the dust spot efficiency increases, the diameter of glass fibers is reduced, and they are placed closer together.
- Extended surfaces, such as pleated mats or bags, are used to increase the surface area of the medium as shown in [Figure 9.7.4\(b\)](#). Air velocity through the medium is 6 to 90 fpm. Face velocity of the air filter is about 500 fpm to match the face velocity of the coil in AHUs and PUs.
- Initial pressure drop varies from 0.20 to 0.60 in. WG and final pressure drop from 0.50 to 1.20 in. WG.

High-Efficiency Particulate Air (HEPA) Filters and Ultra-Low-Penetration Air (ULPA) Filters

HEPA filters have a DOP test efficiency of 99.97% for dust particles $\geq 0.3 \mu\text{m}$ in diameter. *ULPA filters* have a DOP test efficiency of 99.999% for dust particles $\geq 0.12 \mu\text{m}$ in diameter.

A typical HEPA filter, shown in [Figure 9.7.4\(d\)](#), has dimensions of $24 \times 24 \times 11.5$ in. Its filter media are made of glass fibers of submicrometer diameter in the form of pleated paper mats. The medium is dry and disposable. The surface area of the HEPA filter may be 50 times its face area, and its rated face velocity varies from 190 to 390 fpm, normally at a pressure drop of 0.50 to 1.35 in. WG for clean filters. The final pressure drop is 0.8 to 2 in. WG. Sealing of the filter pack within its frame and sealing between the frame and the gaskets are critical factors that affect the penetration and efficiency of the HEPA filter.

An ULPA filter is similar to a HEPA filter in construction and filter media. Both its sealing and filter media are more efficient than those of a HEPA filter.

To extend the service life of HEPA filters and ULPA filters, both should be protected by a medium-efficiency filter, or a low-efficiency and a medium-efficiency filter in the sequence low–medium just before the HEPA or ULPA filters. HEPA and ULPA filters are widely used in clean rooms and clean spaces.

Activated Carbon Filters

These filters are widely used to remove objectional odors and irritating gaseous airborne particulates, typically 0.003 to 0.006 μm in size, from the air stream by adsorption. *Adsorption* is physical condensation of gas or vapor on the surface of an activated substance like activated carbon. Activated substances are extremely porous. One pound of activated carbon contains 5,000,000 ft^2 of internal surface.

Activated carbon in the form of granules or pellets is made of coal, coconut shells, or petroleum residues and is placed in trays to form activated carbon beds as shown in [Figure 9.7.4\(d\)](#). A typical carbon tray is $23 \times 23 \times 5/8$ in. thick. Low-efficiency prefilters are used for protection. When air flows through the carbon beds at a face velocity of 375 to 500 fpm, the corresponding pressure drop is 0.2 to 0.3 in. WG.

Humidifiers

A *humidifier* adds moisture to the air. Air is humidified by: (1) heating the liquid to evaporate it; (2) atomizing the liquid water into minute droplets by mechanical means, compressed air, or ultrasonic vibration to create a larger area for evaporation; (3) forcing air to flow through a wetted element in

which water evaporates; and (4) injecting steam into air directly before it is supplied to the conditioned space.

For comfort air-conditioning systems, a steam humidifier with a separator as shown in Figure 9.7.5(a) is widely used. Steam is supplied to a jacketed distribution manifold. It enters a separating chamber with its condensate. Steam then flows through a control valve, throttles to a pressure slightly above atmospheric, and enters a dry chamber. Due to the high temperature in the surrounding separating chamber, the steam is superheated. Dry steam is then discharged into the ambient air stream through the orifices on the inner steam discharge tubes.

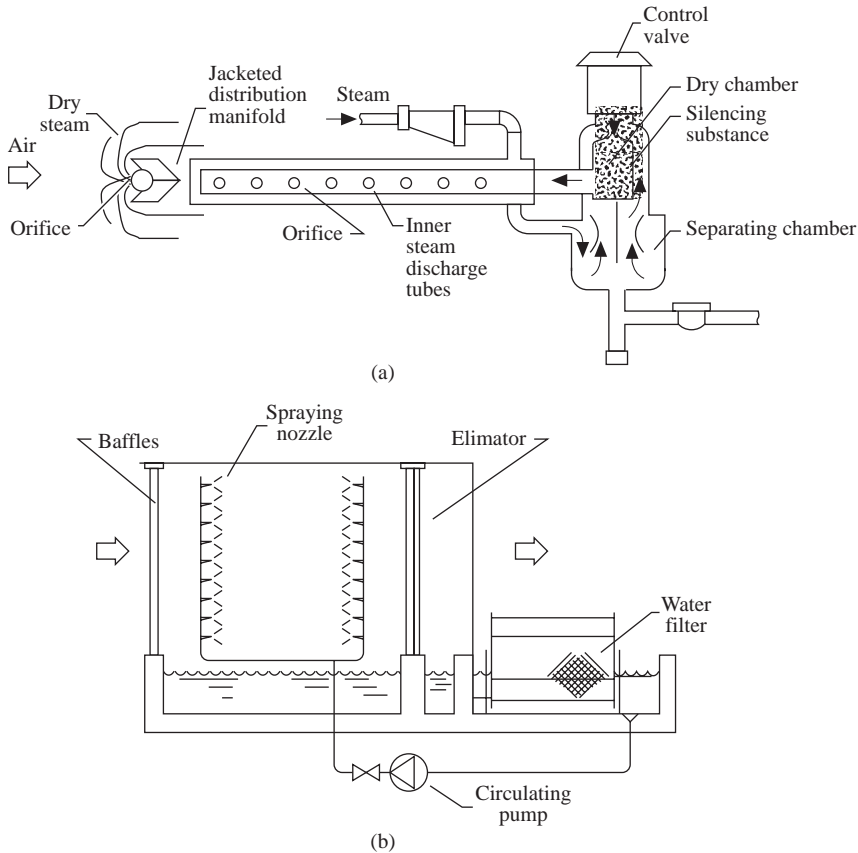

FIGURE 9.7.5 Steam grid humidifier (a) and air washer (b).

For an air system of cold air supply with humidity control during winter mode operation, an air washer is economical for large-capacity humidification in many industrial applications.

An air washer is a humidifier, a cooler, a dehumidifier, and an air cleaner. An air washer usually has an outer casing, two banks of spraying nozzles, one bank of guide baffles at the entrance, one bank of eliminators at the exit, a water tank, a circulating pump, a water filter, and other accessories as shown in Figure 9.7.5(b). Outer casing, baffles, and eliminators are often made of plastics or sometimes stainless steel. Spraying nozzles are usually made of brass or nylon, with an orifice diameter of 1/16 to 3/16 in., a smaller orifice for humidification, and a larger orifice for cooling and dehumidification. An eccentric inlet connected to the discharge chamber of the spraying nozzle gives centrifugal force to the water stream and atomizes the spraying water. Water is supplied to the spraying nozzle at a pressure of 15 to 30 psig. The distance between two spraying banks is 3 to 4.5 ft, and the total length of the air water from 4 to 7 ft. The air velocity inside an air washer is usually 500 to 800 fpm.

Selection of AHUs and PUs

- The size of an AHU is usually selected so that the face velocity of its coil is 600 fpm or less in order to prevent entrained condensate droplets. The cooling and heating capacities of an AHU can be varied by using coils of different numbers of rows and fin densities. The size of a PU is determined by its cooling capacity. Normally, the volume flow rate per ton of cooling capacity in PUs is 350 to 400 cfm. In most packaged units whose supply fans have belt drives, the fan speed can be selected so that the volume flow rate is varied and external pressure is met.
- ASHRAE/IES Standard 90.1-1989 specifies that the selected equipment capacity may exceed the design load only when it is the smallest size needed to meet the load. Selected equipment in a size larger always means a waste of energy and investment.
- To improve the indoor air quality, save energy, and prevent smudging and discoloring building interiors, a medium-efficiency filter of dust spot efficiency $\geq 50\%$ and an air economizer are preferable for large AHUs and PUs.

9.8 Refrigeration Components and Evaporative Coolers

Refrigeration Compressors

A *refrigeration compressor* is the heart of a vapor compression system. It raises the pressure of refrigerant so that it can be condensed into liquid, throttled, and evaporated into vapor to produce the refrigeration effect. It also provides the motive force to circulate the refrigerant through condenser, expansion valve, and evaporator.

According to the compression process, refrigeration compressors can be divided into *positive displacement* and *nonpositive displacement* compressors. A positive displacement compressor increases the pressure of the refrigerant by reducing the internal volume of the compression chamber. Reciprocating, scroll, rotary, and screw compressors are all positive displacement compressors. The centrifugal compressor is the only type of nonpositive displacement refrigeration compressor widely used in refrigeration systems today.

Based on the sealing of the refrigerant, refrigeration compressors can be classified as

- *Hermetic compressors*, in which the motor and the compressor are sealed or welded in the same housing to minimize leakage of refrigerant and to cool the motor windings by using suction vapor
- *Semihermetic compressors*, in which motor and compressor are enclosed in the same housing but are accessible from the cylinder head for repair and maintenance
- *Open compressors*, in which compressor and motor are enclosed in two separate housings

Refrigeration compressors are often driven by motor directly or by gear train.

Performance Indices

Volumetric efficiency η_v of a refrigeration compressor is defined as

$$\eta_v = \dot{V}_{a,v} / \dot{V}_p \quad (9.8.1)$$

where $\dot{V}_{a,v}$ = actual induced volume of the suction vapor at suction pressure, cfm
 \dot{V}_p = calculated displacement of the compressor, cfm

Isentropic efficiency η_{isen} , *compression efficiency* η_{cp} , *compressor efficiency* η_{com} , and *mechanical efficiency* η_{mec} are defined as

$$\begin{aligned} \eta_{isen} &= (h_2 - h_1) / (h'_2 - h_1) = \eta_{cp} \eta_{mec} = \eta_{com} \\ \eta_{cp} &= W_{sen} / W_v \\ \eta_{mec} &= W_v / W_{com} \end{aligned} \quad (9.8.2)$$

where h_1, h_2, h'_2 = enthalpy of the suction vapor, ideal discharged hot gas, and actual discharged hot gas, respectively, Btu/lb

W_{isen}, W_v, W_{com} = isentropic work = $(h_2 - h_1)$, work delivered to the vapor refrigerant, and work delivered to the compressor shaft, Btu/lb

The actual power input to the compressor P_{com} , in hp, can be calculated as

$$\begin{aligned} P_{com} &= \dot{m}_r (h_2 - h_1) / (42.41 \eta_{isen} \eta_{mo}) \\ \dot{m}_r &= \dot{V}_p \eta_v \rho_{suc} \\ \eta_{mo} &= P_{com} / P_{mo} \end{aligned} \quad (9.8.3)$$

where \dot{m}_r = mass flow rate of refrigerant, lb/min
 ρ_{suc} = density of suction vapor, lb/ft³
 P_{mo} = power input to the compressor motor, hp

Power consumption, kW/ton refrigeration, is an energy index used in the HVAC&R industry in addition to EER and COP.

Currently used refrigeration compressors are reciprocating, scroll, screw, rotary, and centrifugal compressors.

Reciprocating Compressors

In a reciprocating compressor, as shown in [Figure 9.8.1\(a\)](#), a crankshaft connected to the motor shaft drives 2, 3, 4, or 6 single-acting pistons moving reciprocally in the cylinders via a connecting rod.

The refrigeration capacity of a reciprocating compressor is a fraction of a ton to about 200 tons. Refrigerants R-22 and R-134a are widely used in comfort and processing systems and sometimes R-717 in industrial applications. The maximum compression ratio R_{com} for a single-stage reciprocating compressor is about 7. Volumetric efficiency η_v drops from 0.92 to 0.65 when R_{com} is raised from 1 to 6. Capacity control of reciprocating compressor including: on-off and cylinder unloader in which discharge gas is in short cut and return to the suction chamber.

Although reciprocating compressors are still widely used today in small and medium-sized refrigeration systems, they have little room for significant improvement and will be gradually replaced by scroll and screw compressors.

Scroll Compressors

A scroll compressor consists of two identical spiral scrolls assembled opposite to each other, as shown in [Figure 9.8.1\(b\)](#). One of the scrolls is fixed, and the other moves in an orbit around the motor shaft whose amplitude equals the radius of the orbit. The two scrolls are in contact at several points and therefore form a series of pockets.

Vapor refrigerant enters the space between two scrolls through lateral openings. The lateral openings are then sealed and the formation of the two trapped vapor pockets indicates the end of the suction process. The vapor is compressed and the discharge process begins when the trapped gaseous pockets open to the discharge port. Compressed hot gas is then discharged through this opening to the discharge line. In a scroll compressor, the scrolls touch each other with sufficient force to form a seal but not enough to cause wear.

The upper limit of the refrigeration capacity of currently manufactured scroll compressors is 60 tons. A scroll compressor has $\eta_v > 95\%$ at $R_{\text{com}} = 4$ and $\eta_{\text{isen}} = 80\%$. A scroll compressor also has only about half as many parts as a reciprocating compressor at the same refrigeration capacity. Few components result in higher reliability and efficiency. Power input to the scroll compressor is about 5 to 10% less than to the reciprocating compressor. A scroll compressor also operates more smoothly and is quieter.

Rotary Compressors

Small rotary compressors for room air conditioners and refrigerators have a capacity up to 4 tons. There are two types of rotary compressors: rolling piston and rotating vane. A typical rolling piston rotary compressor is shown in [Figure 9.8.1\(c\)](#). A rolling piston mounted on an eccentric shaft is kept in contact with a fixed vane that slides in a slot. Vapor refrigerant enters the compression chamber and is compressed by the eccentric motion of the roller. When the rolling piston contacts the top housing, hot gas is squeezed out from the discharge valve.

Screw Compressors

These are also called *helical rotary compressors*. Screw compressors can be classified into single-screw compressors, in which there is a single helical rotor and two star wheels, and twin-screw compressors. Twin-screw compressors are widely used.

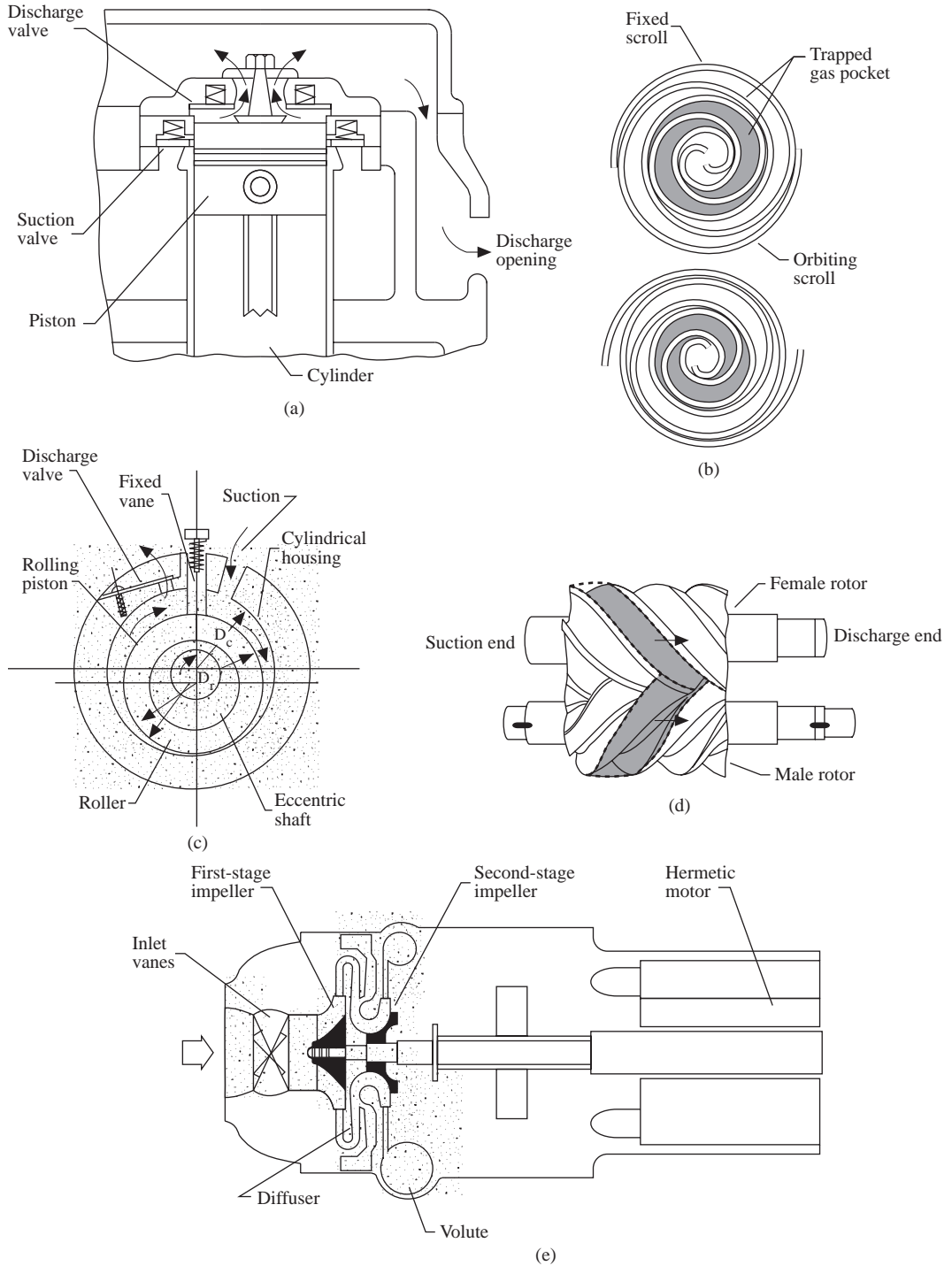

FIGURE 9.8.1 Various types of refrigeration compressors: (a) reciprocating, (b) scroll, (c) rotary, (d) twin-screw, and (e) centrifugal.

A typical twin-screw compressor, as shown in [Figure 9.8.1\(d\)](#) consists of a four-lobe male rotor and a six-lobe female rotor, a housing with suction and discharge ports, and a sliding valve to adjust the

capacity during part load. Normally, the male rotor is the driver. Twin-screw compressors are often direct driven and of hermetic type.

Vapor refrigerant is extracted into the interlobe space when the lobes are separated at the suction port. During the successive rotations of the rotor, the volume of the trapped vapor is compressed. When the interlobe space is in contact with the discharge port, the compressed hot gas discharges through the outlet. Oil injection effectively cools the rotors and results in a lower discharge temperature. Oil also provides a sealing effect and lubrication. A small clearance of 0.0005 in. as well as the oil sealing minimizes leakage of the refrigerant.

The refrigeration capacity of twin-screw compressors is 50 to 1500 tons. The compression ratio of a twin-screw compressor can be up to 20:1. R-22 and R-134a are the most widely used refrigerants in comfort systems. In a typical twin-screw compressor, η_v decreases from 0.92 to 0.87 and η_{isen} drops from 0.82 to 0.67 when R_{com} increases from 2 to 10. Continuous and stepless capacity control is provided by moving a sliding valve toward the discharge port, which opens a shortcut recirculating passage to the suction port.

Twin-screw compressors are more efficient than reciprocating compressors. The low noise and vibration of the twin-screw compressor together with its positive displacement compression results in more applications today.

Centrifugal Compressors

A *centrifugal compressor* is a turbomachine and is similar to a centrifugal fan. A hermetic centrifugal compressor has an outer casing with one, two, or even three impellers internally connected in series and is driven by a motor directly or by a gear train. At the entrance to the first-stage impeller are inlet guide vanes positioned at a specific opening to adjust refrigerant flow and therefore the capacity of the centrifugal compressor.

Figure 9.8.1(e) shows a two-stage hermetic centrifugal compressor. The total pressure rise in a centrifugal compressor, often called head lift, in psi, is due to the conversion of the velocity pressure into static pressure. Although the compression ratio R_{com} of a single-stage centrifugal compressor using R-123 and R-22 seldom exceeds 4, two or three impellers connected in series satisfy most of the requirements in comfort systems.

Because of the high head lift to raise the evaporating pressure to condensing pressure, the discharge velocity at the exit of the second-stage impeller approaches the acoustic velocity of saturated vapor v_{ac} of R-123, 420 ft/sec at atmospheric pressure and a temperature of 80°F. Centrifugal compressors need high peripheral velocity and rotating speeds (up to 50,000 rpm) to produce such a discharge velocity. It is not economical to manufacture small centrifugal compressors. The available refrigeration capacity for centrifugal compressors ranges from 100 to 10,000 tons. Centrifugal compressors have higher volume flow per unit refrigeration capacity output than positive displacement compressors. Centrifugal compressors are efficient and reliable. Their volumetric efficiency almost equals 1. At design conditions, their η_{isen} may reach 0.83, and it drops to 0.6 during part-load operation. They are the most widely used refrigeration compressors in large air-conditioning systems.

Refrigeration Condensers

A *refrigeration condenser* or simply a *condenser* is a heat exchanger in which hot gaseous refrigerant is condensed into liquid and the latent heat of condensation is rejected to the atmospheric air, surface water, or well water. In a condenser, hot gas is first desuperheated, then condensed into liquid, and finally subcooled.

The capacity of a condenser is rated by its *total heat rejection* Q_{rej} , in Btu/hr, which is defined as the total heat removed from the condenser during desuperheating, condensation, and subcooling. For a refrigeration system using a hermetic compressor, Q_{rej} can be calculated as

$$\dot{Q}_{\text{rej}} = U_{\text{con}} A_{\text{con}} \Delta T_m = 60 \dot{m}_r (h_2 - h'_3) = q_{\text{rl}} + (2545 P_{\text{com}}) / \eta_{\text{mo}} \quad (9.8.4)$$

where U_{con} = overall heat transfer coefficient across the tube wall in the condenser, Btu/hr.ft².°F
 A_{con} = condensing area in the condenser, ft²
 ΔT_m = logarithmic temperature difference, °F
 \dot{m}_r = mass flow rate of refrigerant, lb/min
 h_2, h'_3 = enthalpy of suction vapor refrigerant and hot gas, Btu/lb
 q_{rl} = refrigeration load at the evaporator, Btu/hr

A factor that relates \dot{Q}_{rej} and q_{rl} is the *heat rejection factor* F_{rej} , which is defined as the ratio of total heat rejection to the refrigeration load, or

$$F_{\text{rej}} = \dot{Q}_{\text{rej}} / q_{\text{rl}} = 1 + (2545 P_{\text{com}}) / (q_{\text{rl}} \eta_{\text{mo}}) \quad (9.8.5)$$

Fouling factor R_f , in hr.ft².°F/Btu, is defined as the additional resistance caused by a dirty film of scale, rust, or other deposits on the surface of the tube. ARI Standard 550-88 specifies the following for evaporators and condensers:

Field fouling allowance	0.00025 hr.ft ² .°F/Btu
New evaporators and condensers	0

According to the cooling process used during condensation, refrigeration condensers can be classified as air-cooled, water-cooled, and evaporative-cooled condensers.

Air-Cooled Condensers

In an *air-cooled condenser*, air is used to absorb the latent heat of condensation released during desuperheating, condensation, and subcooling.

An air-cooled condenser consists of a condenser coil, a subcooling coil, condenser fans, dampers, and controls as shown in Figure 9.8.2(a). There are refrigeration circuits in the condensing coil. Condensing coils are usually made of copper tubes and aluminum fins. The diameter of the tubes is 1/4 to 3/4 in., typically 3/8 in., and the fin density is 8 to 20 fins/in. On the inner surface of the copper tubes, microfins, typically 60 fins/in. with a height of 0.008 in., are used. A condensing coil usually has only two to three rows due to the low pressure drop of the propeller-type condenser fans. A subcooling coil is located at a lower level and is connected to the condensing coil.

Hot gas from the compressor enters the condensing coil from the top. When the condensate increases, part of the condensing area can be used as a subcooling area. A receiver is necessary only when the liquid refrigerant cannot all be stored in the condensing and subcooling coils during the shut-down period in winter.

Cooling air is drawn through the coils by a condenser fan(s) for even distribution. Condenser fans are often propeller fans for their low pressure and large volume flow rate. A damper(s) may be installed to adjust the volume flow of cooling air.

In air-cooled condensers, the volume flow of cooling air per unit of total heat rejection $\dot{V}_{\text{ca}} / \dot{Q}_{\text{u.rej}}$ is 600 to 1200 cfm/ton of refrigeration capacity at the evaporator, and the optimum value is about 900 cfm/ton. The corresponding cooling air temperature difference — cooling air leaving temperature minus outdoor temperature ($T_{\text{ca,l}} - T_o$) — is around 13°F.

The condenser temperature difference (CTD) for an air-cooled condenser is defined as the difference between the saturated condensing temperature corresponding to the pressure at the inlet and the air intake temperature, or ($T_{\text{con,i}} - T_o$). Air-cooled condensers are rated at a specific CTD, depending on the evaporating temperature of the refrigeration system T_{ev} in which the air-cooled condenser is installed. For a refrigeration system having a lower T_{ev} , it is more economical to equip a larger condenser with a smaller CTD. For a comfort air-conditioning system having a T_{ev} of 45°F, CTD = 20 to 30°F.

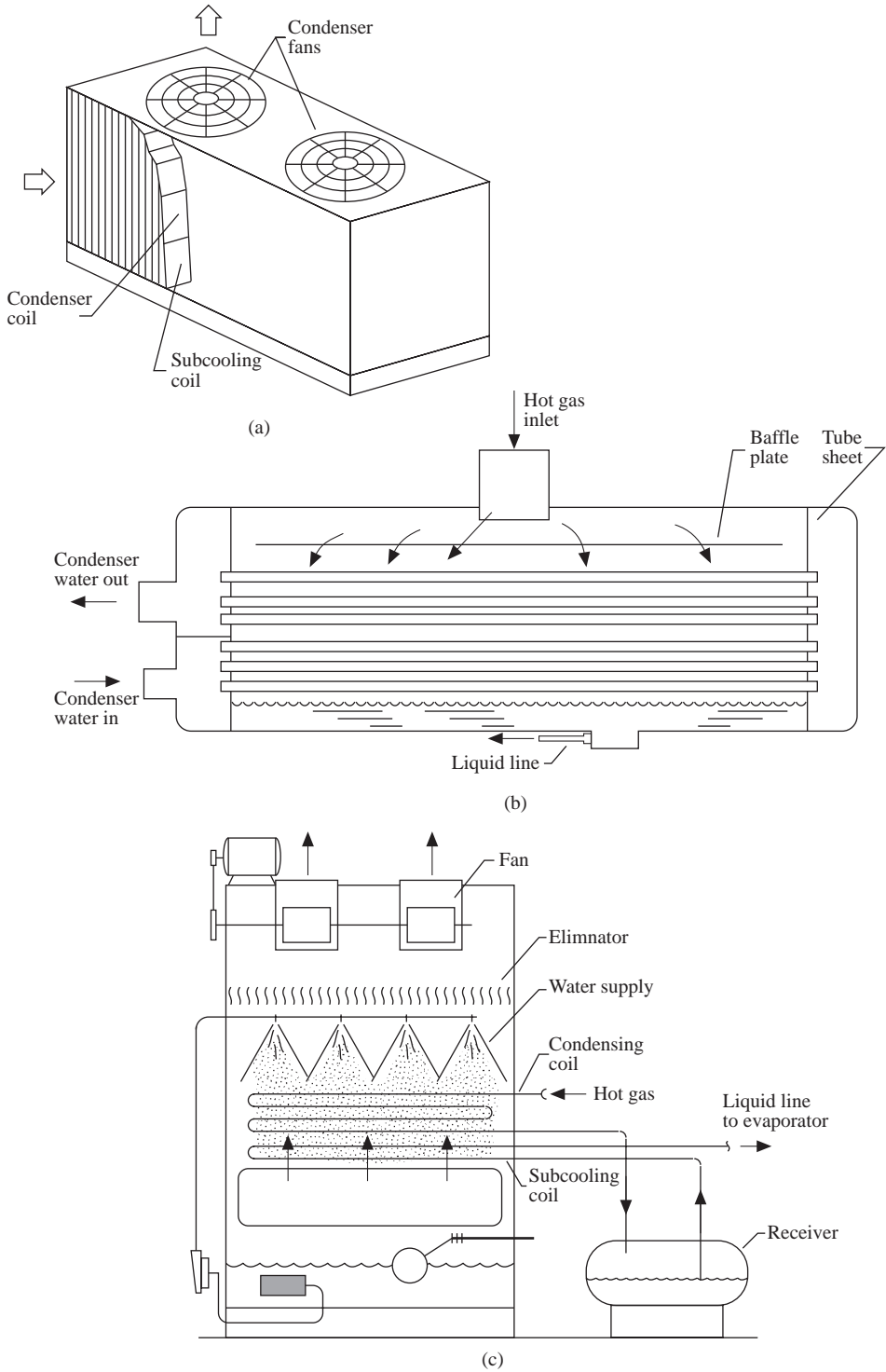

FIGURE 9.8.2 Various types of refrigeration condensers: (a) air-cooled, (b) shell-and-tube water-cooled, and (c) evaporative cooled.

A higher condensing temperature T_{con} , a higher condensing pressure p_{con} , and a higher compressor power input may be due to an undersized air-cooled condenser, lack of cooling air or low $\dot{V}_{\text{ca}}/Q_{\text{u,rej}}$ value, a high entering cooling air temperature at the roof, a dirty condensing coil, warm air circulation because of insufficient clearance between the condenser and the wall, or a combination of these. The clearance should not be less than the width of the condensing coil.

If p_{con} drops below a certain value because of a lower outdoor temperature, the expansion valve in a reciprocating vapor compression system may not operate properly. At a low ambient temperature T_o , the following controls are often used:

- Duty cycling, turning the condenser fans on and off until all of them are shut down, to reduce cooling air volume flow
- Modulating the air dampers to reduce the volume flow
- Reducing the fan speed

Some manufacturers' catalogs start low ambient control at $T_o = 65^\circ\text{F}$ and some specify a minimum operating temperature at $T_o = 0^\circ\text{F}$.

Water-Cooled Condensers

In a *water-cooled condenser*, latent heat of condensation released from the refrigerant during condensation is extracted by water. This cooling water, often called condenser water, is taken directly from river, lake, sea, underground well water or a cooling tower.

Two types of water-cooled condensers are widely used for air-conditioning and refrigeration: double-tube condensers and horizontal shell-and-tube condensers.

A *double-tube condenser* consists of two tubes, one inside the other. Condenser water is pumped through the inner tube and refrigerant flows within the space between the inner and outer tubes in a counterflow arrangement. Because of its limited condensing area, the double-tube condenser is used only in small refrigeration systems.

A horizontal *shell-and-tube water-cooled condenser* using halocarbon refrigerant usually has an outer shell in which copper tubes typically 5/8 to 3/4 in. in diameter are fixed in position by tube sheets as shown in [Figure 9.8.2\(b\)](#). Integral external fins of 19 to 35 fins/in. and a height of 0.006 in. and spiral internal grooves are used for copper tubes to increase both the external and the inner surface area and their heat transfer coefficients.

Hot gas from the compressor enters the top inlet and is distributed along the baffle to fill the shell. Hot gas is then desuperheated, condensed, subcooled into liquid, and discharged into the liquid line at the bottom outlet. Usually one sixth of the volume is filled with subcooled liquid refrigerant. Subcooling depends on the entering temperature of condenser water T_{ce} , in $^\circ\text{F}$, and usually varies between 2 and 8 $^\circ\text{F}$.

Condenser water enters the condenser from the bottom for effective subcooling. After extracting heat from the gaseous refrigerant, condenser water is discharged at a higher level. Two-pass or three-pass water flow arrangements are usually used in shell-and-tube water-cooled condensers. The two-pass arrangement means that water flows from one end to the opposite end and returns to the original end. Two-pass is the standard setup. In a shell-and-tube water-cooled condenser, the condensing temperature T_{con} depends mainly on the entering temperature of condenser water T_{ce} , the condenser area, the fouling factor, and the configuration of the copper tube.

Evaporative Condenser

An *evaporative condenser* uses the evaporation of water spray on the outer surface of the condensing tubes to remove the latent heat of condensation of refrigerant during condensation.

An evaporative condenser consists of a condensing coil, a subcooling coil, a water spray, an induced draft or sometimes forced draft fan, a circulating water pump, a water eliminator, a water basin, an outer casing, and controls as shown in [Figure 9.8.2\(c\)](#). The condensing coil is usually made of bare copper, steel, or sometimes stainless steel tubing.

Water is sprayed over the outside surface of the tubing. The evaporation of a fraction of condenser water from the saturated air film removes the sensible and latent heat rejected by the refrigerant. The wetted outer surface heat transfer coefficient h_{wet} is about four or five times greater than the dry surface heat transfer coefficient h_o , in Btu/hr.ft².°F. The rest of the spray falls and is collected by the basin. Air enters from the inlet just above the basin. It flows through the condensing coil at a face velocity of 400 to 700 fpm, the water spray bank, and the eliminator. After air absorbs the evaporated water vapor, it is extracted by the fan and discharged at the top outlet. The water circulation rate is about 1.6 to 2 gpm/ton, which is far less than that of the cooling tower.

An evaporative condenser is actually a combination of a water-cooled condenser and a cooling tower. It is usually located on the rooftop and should be as near the compressor as possible. Clean tube surface and good maintenance are critical factors for evaporative condensers. An evaporative condenser also needs low ambient control similar as in an air-cooled condenser.

Comparison of Air-Cooled, Water-Cooled, and Evaporative Condensers

An air-cooled condenser has the highest condensing temperature T_{con} and therefore the highest compressor power input. For an outdoor dry bulb temperature of 90°F and a wet bulb temperature of 78°F, a typical air-cooled condenser has $T_{\text{con}} = 110^\circ\text{F}$. An evaporative condenser has the lowest T_{con} and is most energy efficient. At the same outdoor dry and wet bulb temperatures, its T_{con} may be equal to 95°F, even lower than that of a water-cooled condenser incorporating with a cooling tower, whose T_{con} may be equal to 100°F. An evaporative condenser also consumes less water and pump power. The drawback of evaporative condensers is that the rejected heat from the interior zone is difficult to recover and use as winter heating for perimeter zones and more maintenance is required.

Evaporators and Refrigerant Flow Control Devices

An *evaporator* is a heat exchanger in which the liquid refrigerant is vaporized and extracts heat from the surrounding air, chilled water, brine, or other substance to produce a refrigeration effect.

Evaporators used in air-conditioning can be classified according to the combination of the medium to be cooled and the type of refrigerant feed, as the following.

Direct expansion DX coils are air coolers, and the refrigerant is fed according to its degree of superheat after vaporization. DX coils were covered earlier.

Direct expansion ice makers or *liquid overfeed ice makers* are such that liquid refrigerant is forced through the copper tubes or the hollow inner part of a plate heat exchanger and vaporized. The refrigeration effect freezes the water in the glycol-water that flows over the outside surface of the tubes or the plate heat exchanger. In direct expansion ice makers, liquid refrigerant completely vaporizes inside the copper tubes, and the superheated vapor is extracted by the compressor. In liquid overfeed ice makers, liquid refrigerant floods and wets the inner surface of the copper tubes or the hollow plate heat exchanger. Only part of the liquid refrigerant is vaporized. The rest is returned to a receiver and pumped to the copper tubes or plate heat exchanger again at a circulation rate two to several times greater than the evaporation rate.

Flooded shell-and-tube liquid coolers, or simply *flooded liquid coolers*, are such that refrigerant floods and wets all the boiling surfaces and results in high heat transfer coefficients. A flooded shell-and-tube liquid cooler is similar in construction to a shell-and-tube water-cooled condenser, except that its liquid refrigeration inlet is at the bottom and the vapor outlet is at the top. Water velocity inside the copper tubes is usually between 4 and 12 ft/sec and the water-side pressure normally drops below 10 psi. Flooded liquid coolers can provide larger evaporating surface area and need minimal space. They are widely used in large central air-conditioning systems.

Currently used refrigerant flow control devices include thermostatic expansion valves, float valves, multiple orifices, and capillary tubes.

A *thermostatic expansion valve* throttles the refrigerant pressure from condensing to evaporating pressure and at the same time regulates the rate of refrigerant feed according to the degree of superheat

of the vapor at the evaporator's exit. A thermostatic expansion valve is usually installed just prior to the refrigerant distributor in DX coils and direct-expansion ice makers.

A thermostatic expansion valve consists of a valve body, a valve pin, a spring, a diaphragm, and a sensing bulb near the outlet of the DX coil, as shown in Figure 9.7.3(a). The sensing bulb is connected to the upper part of the diaphragm by a connecting tube.

When the liquid refrigerant passes through the opening of the thermostatic expansion valve, its pressure is reduced to the evaporating pressure. Liquid and a small fraction of vaporized refrigerant then flow through the distributor and enter various refrigerant circuits. If the refrigeration load of the DX coil increases, more liquid refrigerant evaporizes. This increases the degree of superheat of the leaving vapor at the outlet and the temperature of the sensing bulb. A higher bulb temperature exerts a higher saturated pressure on the top of the diaphragm. The valve pin then moves downward and widens the opening. More liquid refrigerant is allowed to enter the DX coil to match the increase of refrigeration load. If the refrigeration load drops, the degree of superheat at the outlet and the temperature of the sensing bulb both drop, and the valve opening is narrower. The refrigeration feed decreases accordingly. The degree of superheat is usually 10 to 20°F. Its value can also be adjusted manually by varying the spring tension.

A *float valve* is a valve in which a float is used to regulate the valve opening to maintain a specific liquid refrigerant level. A lower liquid level causes a lower valve pin and therefore a wider opening and vice versa.

In a centrifugal refrigeration system, two or more orifice plates, *multiple orifices*, are sometimes installed in the liquid line between the condenser and the flash cooler and between the flash cooler and the flooded liquid cooler to throttle their pressure as well as to regulate the refrigerant feed.

A *capillary tube*, sometimes called a *restrictor tube*, is a fixed length of small-diameter tubing installed between the condenser and the evaporator to throttle the refrigerant pressure from p_{con} to p_{ev} and to meter the refrigerant flow to the evaporator. Capillary tubes are usually made of copper. The inside diameter D_{cap} is 0.05 to 0.06 in. and the length L_{cap} from an inch to several feet. There is a trend to use short capillary tubes of $L_{\text{cap}}/D_{\text{cap}}$ between 3 and 20. Capillary tubes are especially suitable for a heat pump system in which the refrigerant flow may be reversed.

Evaporative Coolers

An evaporative cooling system is an air-conditioning system in which air is cooled evaporatively. It consists of evaporative coolers, fan(s), filters, dampers, controls, and others. A mixing box is optional. An evaporative cooler could be a stand-alone cooler or installed in an air system as a component. There are three types of evaporative coolers: (1) direct evaporative coolers, (2) indirect evaporative coolers, and (3) indirect–direct evaporative coolers.

Direct Evaporative Cooler

In a *direct evaporative cooler*, the air stream to be cooled directly contacts the water spray or wetted medium as shown in Figure 9.8.3(a). Evaporative pads made of wooden fibers with necessary treatment at a thickness of 2 in., rigid and corrugated plastics, impregnated cellulose, or fiber glass all dripping with water are wetted mediums.

The direct evaporation process 12 takes place along the thermodynamic wet bulb line on the psychrometric chart. Saturation effectiveness ϵ_{sat} is an index that assesses the performance of a direct evaporative cooler:

$$\epsilon_{\text{sat}} = (T_{\text{ae}} - T_{\text{al}}) / (T_{\text{ae}} - T_{\text{ae}}^*) \quad (9.8.6)$$

where T , T^* = temperature and thermodynamic wet bulb temperature of air stream, °F. Subscript ae indicates the entering air and al the leaving air. ϵ_{sat} usually varies between 0.75 and 0.95 at a water–air ratio of 0.1 to 0.4.

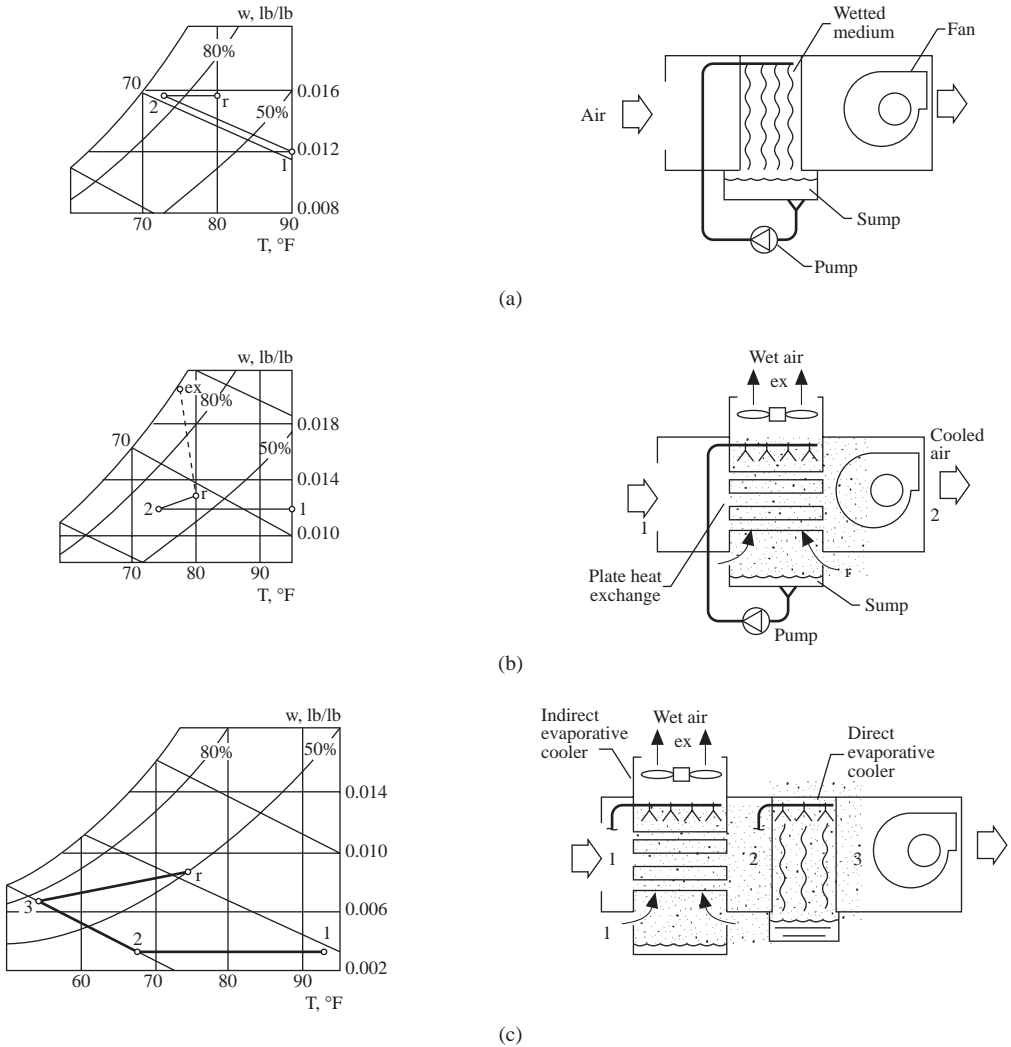

FIGURE 9.8.3 Types of evaporative coolers: (a) direct, (b) indirect, and (c) indirect–direct.

Indirect Evaporative Coolers

In an *indirect evaporative cooler*, the cooled-air stream to be cooled is separated from a wetted surface by a flat plate or tube wall as shown in Figure 9.8.3(b). A wet-air stream flows over the wetted surface so that liquid water is evaporated and extracts heat from the cooled-air stream through the flat plate or tube wall. The cooled-air stream is in contact with the wetted surface indirectly.

The core part of an indirect evaporative cooler is a plate heat exchanger. It is made of thin polyvinyl chloride plates 0.01 in. thick and spaced from 0.08 to 0.12 in. apart to form horizontal passages for cooled air and vertical passages for wet air and water. As in a direct evaporative cooler, there are also fan(s), water sprays, circulating pump, air intake, dampers, controls, etc.

An indirect evaporative cooling process is represented by a horizontal line on a psychrometric chart, which shows that humidity ratio remains constant. If the space air is extracted and used as the wet air intake, the wet air will be exhausted at point x at nearly saturated state.

The performance of an indirect evaporative cooler can be assessed by its performance factor e_{in} , which is calculated as:

$$e_{\text{in}} = (T_{\text{ca,e}} - T_{\text{ca,l}}) / (T_{\text{ca,e}} - T_{\text{s,a}}) \quad (9.8.7)$$

where $T_{\text{ca,e}}$, $T_{\text{ca,l}}$ = temperature of cooled air entering and leaving the indirect evaporative cooler, °F, and $T_{\text{s,a}}$ = temperature of the saturated air film on the wet air side and is about 3°F higher than the wet bulb temperature of the entering air, °F.

An indirect evaporative cooler could be so energy efficient as to provide evaporative cooling with an EER up to 50 instead of 9 to 12 for a reciprocating compression refrigeration system.

Direct–Indirect Evaporative Cooler. A direct–indirect evaporative cooler is a two-stage evaporating cooler, as shown in [Figure 9.8.3\(c\)](#), in which the first-stage indirect evaporative cooler is connected in series with a second-stage direct evaporative cooler for the purpose of increasing the evaporating effect.

Operating Characteristics. The saturation effectiveness ϵ_{sat} and performance factor e_{in} are both closely related to the air velocity flowing through the air passages. For a direct evaporative cooler, face velocity is usually less than 600 fpm to reduce drift carryover. For an indirect evaporative cooler, face velocity v_s is usually between 400 to 1000 fpm. A higher v_s results at a greater air-side pressure drop.

Scofield et al. (1984) reported the performance of an indirect–direct evaporative cooler in Denver, Colorado. Outdoor air enters the indirect cooler at a dry bulb of 93°F and a wet bulb of 67.5° and was evaporatively cooled to 67.5°F dry bulb and 49.8°F wet bulb with an $e_{\text{in}} = 0.76$ as shown in [Figure 9.8.3\(c\)](#). In the direct cooler, conditioned air was further cooled to a dry bulb of 53.5°F and the wet bulb remained at 49.8°F at a saturation effectiveness $\epsilon_{\text{sat}} = 0.8$.

In locations where outdoor wet bulb $T'_o \leq 60^\circ\text{F}$, a direct evaporative can often provide an indoor environment of 78°F and a relative humidity of 60%. In locations $T'_o \leq 68^\circ\text{F}$, an indirect–direct evaporative cooler can maintain a comfortable indoor environment. In locations $T'_o \geq 72^\circ\text{F}$, an evaporative cooler with a supplementary vapor compression refrigeration may be cost effective. Because the installation cost of an indirect–direct cooler is higher than that of refrigeration, cost analysis is required to select the right choice. Evaporative coolers are not suitable for dehumidification except in locations where $T'_o \leq 60^\circ\text{F}$.